



**LUCIFERO**<sup>®</sup>  
ILLUMINAZIONE

IL PECCATO SECONDO LUCIFERO  
2009

LUCIFERO quando la luce illumina il peccato.

Donna e uomo, terra e sole, yin e yang. Le forze della natura si fronteggiano, si scontrano, si incontrano fondendosi nell'umana vita generando enigma ed intrigo.

Non peccato dunque, non mancanza né devianza.

Per la collezione 2009, Lucifero sceglie l'ambiguità dell'essere androgino.

È giunta l'ora di salire le scale, impervia via verso la conoscenza.

La magnificenza della Luce attende.

Dietro la porta suggestioni, emozioni ed impulsi: il pensiero si libera e diventa Arte.

Lucifero when the light illuminates sin.

Woman and man, earth and sky, yin and yang. The forces of nature meet, clashing, coming together melting into human life generating mystery and intrigue.

Therefore not sin, neither absence nor deviance.

For the 2009 collection Lucifero chooses the ambiguity of being androgenous.

The time has come to climb the stairs, an impassable way towards knowledge.

The magnificence of light awaits.

Suggestions, emotions and impulses are just behind the door: thought flies free and becomes art.



Lucifero quand la lumière illumine le péché.

Femme et homme, terre et soleil, yin et yang. Les forces de la nature s'affrontent, se heurtent, se rencontrent, se fondant dans la vie humaine en engendrant énigme et intrigue.

Pas de péché donc, pas de faute ni de déviance.

Pour la collection 2009, Lucifero choisit l'ambigüité de l'être androgyne.

C'est l'heure de monter les escaliers, voie escarpée vers la connaissance.

La magnificence de la Lumière attend.

Derrière la porte, des suggestions, des émotions et des impulsions: la pensée se libère et devient Art.

Lucifero cuando la luz ilumina el pecado.

Mujer y hombre, tierra y sol, yin y yang. Las fuerzas de la naturaleza se afrontan, se enfrentan, se encuentran fundiéndose en la humana vida generando enigma e intriga.

No es pecado entonces, no es falta ni desviación.

Para la colección 2009, Lucifero elige la ambigüedad del ser andrógino.

Ha llegado el momento de subir las escaleras, impracticable camino hacia el conocimiento.

La magnificencia de la Luz espera.

Detrás de la puerta sugerencias, emociones e impulsos: el pensamiento se libera y se convierte en Arte.





TAVOLO  
TABLE

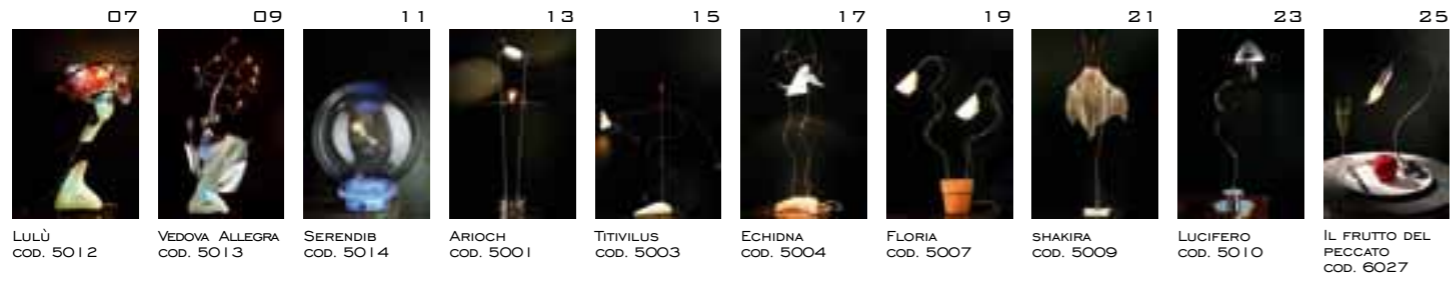

PARETE  
WALL

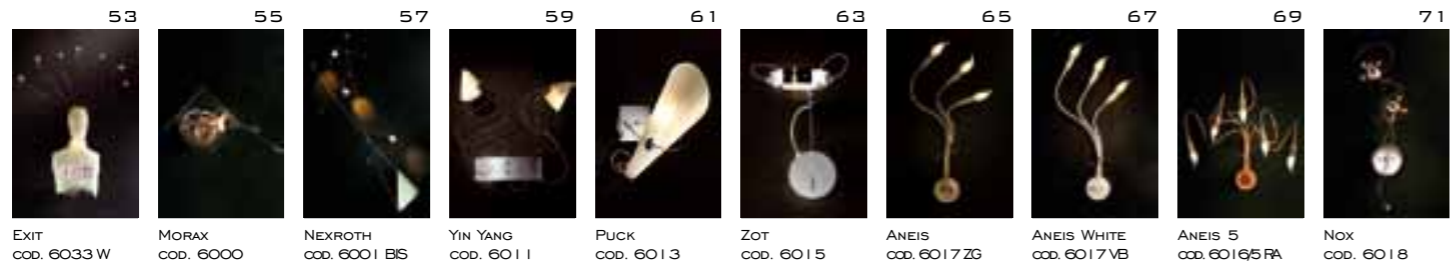

TERRA  
FLOOR



SOSPENSIONE  
SUSPENSION



GIARDINI  
GARDENS



FOLLIE  
MADNESSES



SISTEMA TOTAM  
TOTAM SYSTEM



LED  
LED



CHIBADOS  
COD. LED TA 001

LEDAIR  
COD. 2500 LED

HAYE  
COD. LED AP 003

FIREFAX  
COD. LED AP 002

TUBELED  
COD. LED SO 001

DAHUT  
COD. LED AP 001

YEXA  
COD. LED TA 002

SISTEMA CAVI BASSA TENSIONE 12V  
LOW VOLTAGE CABLE SYSTEM 12V



LEDAIR  
COD. 2500 LED

NATRIX  
COD. 3503 LT

ESOX LUCIUS  
COD. 3506 LT

LAMPRIIS  
COD. 3504 LT

BELONE  
COD. 3505 LT

PAGURUS B.  
COD. 3502 LT

CONGER  
COD. 3501 LT



BAFTIS  
COD. 3002 LT

DARDA  
COD. 3010 LT

EBRON  
COD. 2997 LT

DAGON  
COD. 3006 LT

LANTHILA  
COD. 3009 LT

LUCIOCCHIO  
COD. 3602 LT AR

BITRU  
COD. 3003 LT

CAMOS  
COD. 2998 LT

TALYS  
COD. 3024 LT

OES  
COD. 3025 LT



UPHIR  
COD. 3022 LT

DROES  
COD. 3023 LT

ELFES  
COD. 3021 LT

SALEH  
COD. 3020 LT

HEBEN  
COD. 3018 LT

NIHA  
COD. 3019 LT

FIAMMIFERI  
COD. 3507 LT

CAHOR  
COD. 3004 LT

GERION  
COD. 3005 LT

ZEPAR  
COD. 3000 LT



NETHOS  
COD. 3008 LT

SPIRITELLO  
COD. 3601 LT

COMPONENTI  
SISTEMA BT 12V

SISTEMA COLOMBO 220/240V  
COLOMBO SYSTEM 220/240V



COMBO 1  
COD. CO-1

COMBO 2  
COD. CO-2

COMBO 3  
COD. CO-3

COMBO 4  
COD. CO-4

COMBO 5  
COD. CO-5

COMBO 6  
COD. CO-6

COMBO 7  
COD. CO-7 SLIM

COMBO 7  
COD. CO-7 LARGE

RA II  
COD. CO-8

COMBO 11 N  
COD. CO-11 N



COMBO 12  
COD. CO-12

REPORTAGE  
REPORTAGE



EVENTI  
EVENTS







Base: Metallo cromato  
 Mezzo busto donna: Resina  
 Finitura: Cromo  
 Particolarità: Lampada LED RGB e telecomando per cambio colore  
 Trasformatore: Toroidale inserito nella base  
 Lampadina: Alogena bispina e LED  
 Peso e misure con imballo:  
 6,5 kg - 1.130 x 450 x 260 mm

Base: Chromium plated metal  
 Female bust: Resin  
 Finish: Chrome  
 Detail: LED Lamp RGB and Colour Change Remote Control  
 Transformer: Toroidal within the base  
 Lamp: Double plug-in halogen and LED  
 Weight and Measurements including Packaging:  
 6,5 kg - 1.130 x 450 x 260 mm

Socle: Métal Chromé  
 Demi-Buste Femme: Résine  
 Finition: Chrome  
 Particularité: Lampe LED RGB, Télécommande pour changement de couleur  
 Transformateur: Toroidal inséré dans le socle  
 Ampoule: Halogène bi-pin et LED  
 Poids et mesures avec emballage:  
 6,5 kg - 1.130 x 450 x 260 mm

Base: Metal cromado  
 Medio busto de mujer: Resina  
 Acabado: Cromo  
 Particularidades: Lámpara LED RGB y mando a distancia para cambiar de color  
 Transformador: Toroidal introducido en la base  
 Bombilla: Halógena doble enchufe y LED  
 Peso y medidas con embalaje:  
 6,5 kg - 1.130 x 450 x 260 mm

Cod. 5012

LULÙ

1 x 35W  
 GY6,35 230/1 2V

LAMPADA LED  
 2 x 3W  
 G5,3 230/1 2V

CE IP20

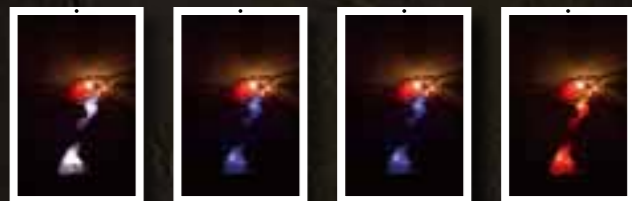

COMMENT RÉSISTER À L'IRONIE FÉMININE?  
 ¿CÓMO SE PUEDE RESISTIR A LA IRONIA FEMENINA?

COME RESISTERE ALL'IRONIA FEMMINILE?  
 HOW CAN ONE RESIST FEMININE IRONY?

LULÙ\_07  
 LUCIFERO





Base: Metallo cromato  
 Mezzo busto donna: Resina  
 Finitura: Cromo  
 Particolarità: Lampada LED RGB e telecomando per cambio colore  
 Trasformatore: Toroidale inserito nella base  
 Lampadina: Alogena bispina e LED  
 Peso e misure con imballo:  
 9 kg - 1.130 x 450 x 260 mm

Base: Chromium plated metal  
 Female bust: Resin  
 Finish: Chrome  
 Détail: LED Lamp RGB and Colour Change Remote Control  
 Transformer: Toroidal within the base  
 Lamp: Double plug-in halogen and LED  
 Weight and Measurements including Packaging:  
 9 kg - 1.130 x 450 x 260 mm

Socle: Métal Chromé  
 Demi-Buste Femme: Résine  
 Finition: Chrome  
 Particularité: Lampe LED RGB, Télécommande pour changement de couleur  
 Transformateur: Toroidal inséré dans le socle  
 Ampoule: Halogène bi-pin et LED  
 Poids et mesures avec emballage:  
 9 kg - 1.130 x 450 x 260 mm

Base: Metal cromado  
 Medio busto mujer: Resina  
 Acabado: Cromo  
 Particularidades: Lámpara LED RGB y mando a distancia para cambiar de color  
 Transformador: Toroidal introducido en la base  
 Bombilla: Halógena doble enchufe y LED  
 Peso y medidas con embalaje:  
 9 kg - 1.130 x 450 x 260 mm

Cod. 5013

VEDOVA ALLEGRA

7 x 10W MAX  
 G4 230/12V

LAMPADA LED  
 2 x 3W  
 G5,3 230/12V

CE IP20

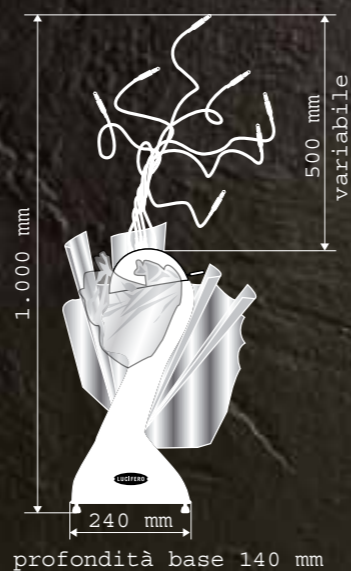

CE SONT LES PENSÉES DE LUMIÈRE QUI RENDENT LA FEMME GUERRIÈRE.  
 SON LOS PENSAMIENTOS DE LUZ QUE HACEN A LA MUJER GUERRERA.



VEDOVA ALLEGRA 09

VEDOVA ALLEGRA

SONO I PENSIERI DI LUCE CHE FANNO LA DONNA GUERRIERO.  
 THOUGHTS OF LIGHT ARE THE MAKING OF THE FEMALE WARRIOR.







Cod. 5014

S E R E N D I B

1 x 60W MAX 12V  
E27 230/12V 

TAPE LED 7,2W



CE IP20   

Base: Plexiglas  
Sfera: Policarbonato  
Particolarità: Pellicola iridescente nella base e  
tape LED blu  
Trasformatore e alimentatore Tape LED:  
inseriti nella base  
Lampadina: a Goccia E27 12V  
Tape LED: Colore blu  
Peso e misure con imballo:  
8 kg - 540 x 540 x 620 mm

Base: Plexiglas  
Sphere: Polycarbonate  
Detail: Iridescent film on base and blue LED tape  
Transformer and LED power supply: Within the base  
LED tape: Blue colour  
Bulb: E27 12V light bulb  
Weight and Measurements including Packaging:  
8 kg - 540 x 540 x 620 mm

Socle: Plexiglas  
Sphère: Polycarbonate  
Particularité: Pellicule iridescente dans le socle  
et LED bleu  
Transformateur et alimentateur: Insérés dans le socle  
Ampoule: Goutte E27 12V  
Tape LED: Couleur bleu  
Poids et mesures avec emballage:  
8 kg - 540 x 540 x 620 mm

Base: Plexiglas  
Esfera: Policarbonato  
Particularidades: Película iridescente en la base  
y Tapas LED azul  
Transformador y alimentador Tapas LED:  
Introducidos en la base  
Bombilla: Gota E27 12V  
Tapas LED: Color azul  
Peso y medidas con embalaje:  
8 kg - 540 x 540 x 620 mm



**SERENDIB** <sub>11</sub>  
 OVER THE HORIZON  
 LUMINOSITÀ

BOULE MAGIQUE: DIS-MOI QUELLE SERA MA LUMIÈRE!  
ESFERA MÁGICA, DIME ¿CUÁL SERÁ MI LUZ?

SFERA MAGICA, DIMMI QUALE SARÀ LA MIA LUCE?  
MAGICAL SPHERE, PLEASE TELL ME WHICH LIGHT WILL BE MINE?





Base: Plexiglas e vetro specchio  
 Stelo: Acciaio  
 Finitura: Cromo  
 Particolarità: Specchio orientabile e sfere cromo nella base  
 Trasformatore: A spina  
 Lampadina: Dicroica  
 Peso e misure con imballo:  
 2,5 kg - 420 x 720 x 120 mm

Base: Plexiglas and glass mirror  
 Stem: Steel  
 Finish: Chrome  
 Detail: Revolving mirror and Chromium spheres in the base  
 Transformer: With plug  
 Lamp: Dichroic  
 Weight and Measurements including Packaging:  
 2.5 kg - 420 x 720 x 120 mm

Socle: Plexiglas et verre miroir  
 Pied: Acier  
 Finition: Chrome  
 Particularité: Miroir orientable et billes chromées à la base  
 Transformateur: À fiche  
 Ampoule: Dichroïque  
 Poids et mesures avec emballage:  
 2,5 kg - 420 x 720 x 120 mm

Base: Plexiglas y cristal espejo  
 Tubo: Acero  
 Acabado: Cromo  
 Particularidades: Espejo orientable y esferas cromadas en la base  
 Transformador: De enchufe  
 Bombilla: Dicroica  
 Peso y medidas con embalaje:  
 2,5 kg - 420 x 720 x 120 mm

Cod. 5001

ARIOCH

35W MAX | 2V Ø35  
 GU4 230/12V

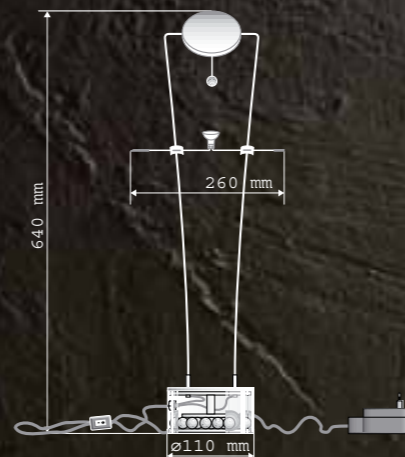

POUR LIRE OU POUR AIMER, LE MIROIR PEUT TOURNER.  
 PARA LEER O AMAR EL ESPEJO PUEDES GIRAR.

PER LEGGERE O AMARE LO SPECCHIO PUOI RUOTARE.  
 TO READ OR TO LOVE, JUST ROTATE THE MIRROR.

ARIOCH 13  
 L'ALBERGHI





Cod. 5003

TITIVILUS

20W MAX | 2V Ø35  
GU4 230/12V



OPZIONE COLORE PUNTA:



Base: Terracotta bianca  
Stelo: Acciaio  
Finitura: Cromo  
Particolarità: Coprilampada in vetro silicone e puntale colorato  
Trasformatore: A spina  
Lampadina: Dicroica  
Peso e misure con imballo:  
2 kg - 420 x 720 x 120 mm

Base: White terra-cotta  
Stem: Steel  
Finish: Chrome  
Detail: Silicone-glass lampshade and coloured point  
Transformer: With plug  
Lamp: Dichroic  
Weight and Measurements including Packaging:  
2 kg - 420 x 720 x 120 mm

Socle: Terre cuite blanche  
Pied: Acier  
Finition: Chrome  
Particularité: Abat-jour en verre siliconé et embout coloré  
Transformateur: À fiche  
Ampoule: Dichroïque  
Poids et mesures avec emballage:  
2 kg - 420 x 720 x 120 mm

Base: Terracota blanca  
Tubo: Acero  
Acabado: Cromo  
Particularidades: Cubrelámpara de cristal silicóna y punta coloreada  
Transformador: De enchufe  
Bombilla: Dicroica  
Peso y medidas con embalaje:  
2 kg - 420 x 720 x 120 mm

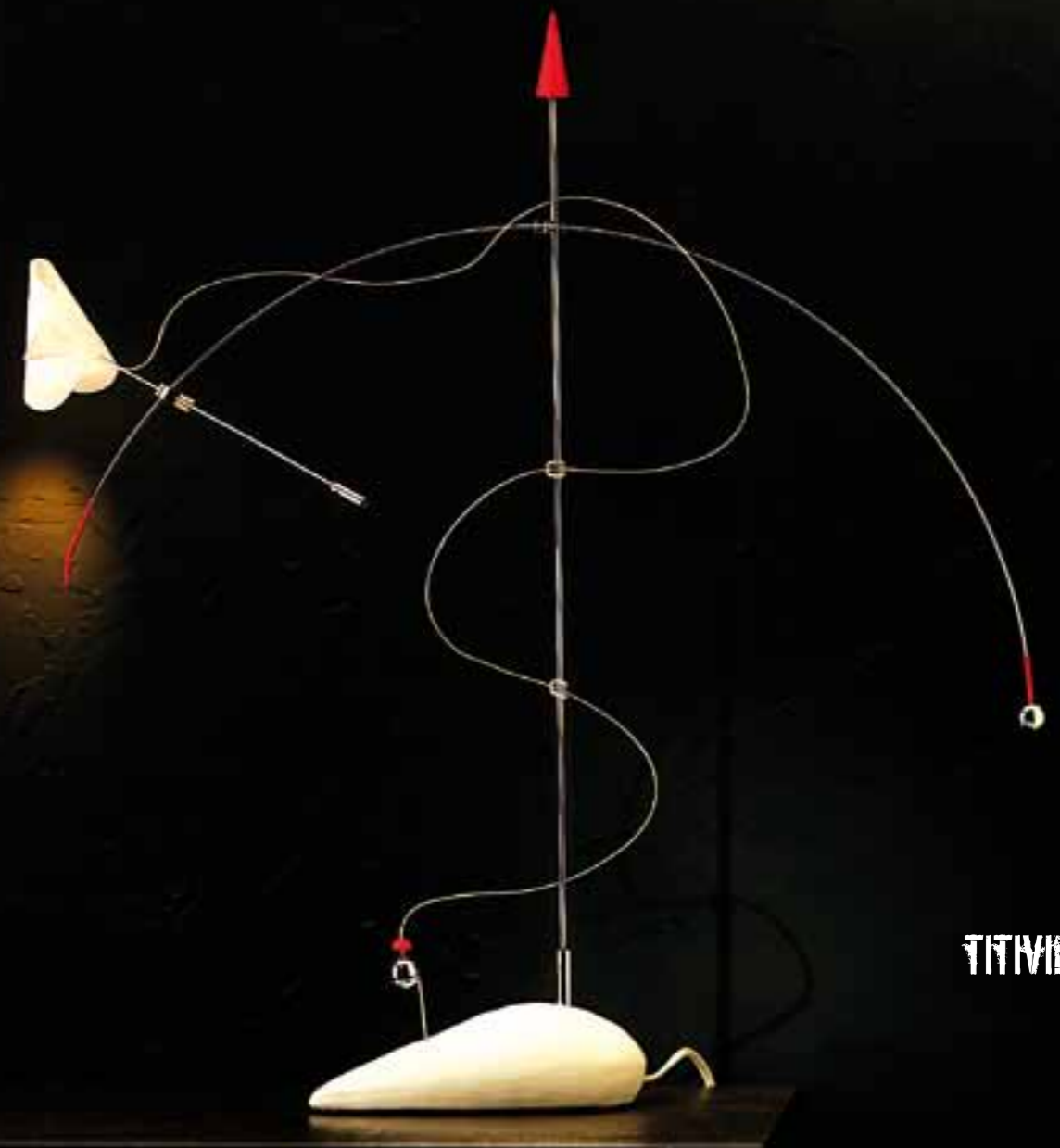
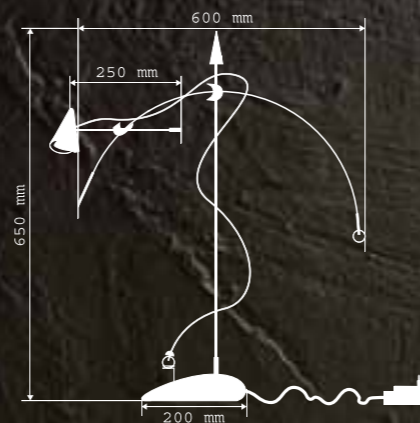

TITIVILUS \_15  
D'ELI DE LUCA  
LUMINERY

ELLE ILLUMINE LE SOIR EN DÉPLAÇANT SIMPLEMENT UNE SPHÈRE.  
ILUMINA LA NOCHE SIMPLEMENTE APARTANDO UNA ESFERA.

ILLUMINA LA SERA SPOSTANDO SEMPLICEMENTE UNA SFERA.  
IT LIGHTS UP THE EVENING, SIMPLY BY MOVING A SPHERE.

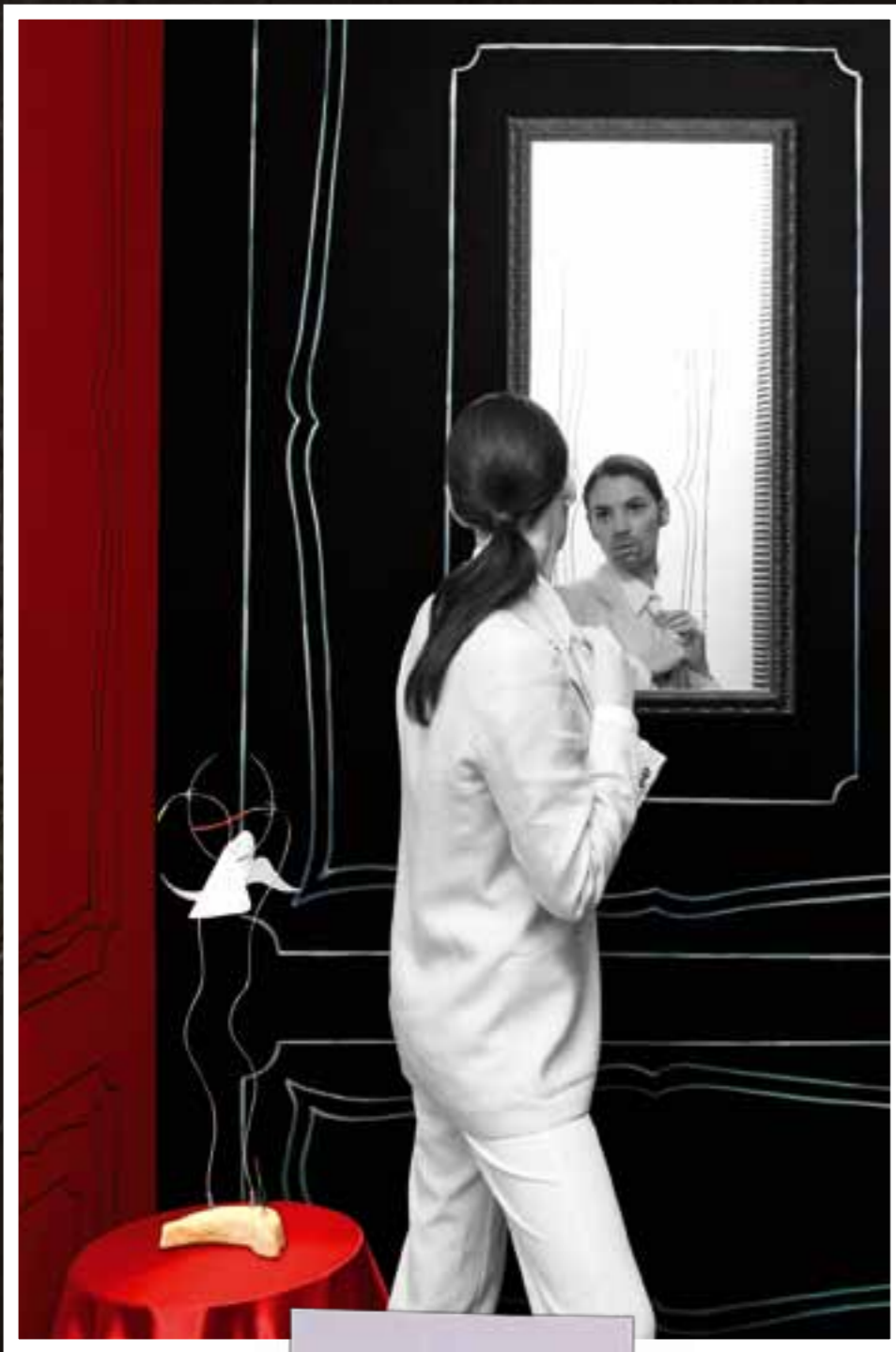

Base: Terracotta rossa  
 Stelo: Rame  
 Finitura: Cromo  
 Particolarità: Coprilampada in vetro silicone  
 Trasformatore: Elettronico inserito nella base  
 Lampadina: Dicroica  
 Peso e misure con imballo:  
 3 kg - 500 x 250 x 800 mm

Base: Red terra-cotta  
 Stem: Copper  
 Finish: Chrome  
 Detail: Silicone-glass  
 lampshade  
 Transformer: Electronic within the base  
 Lamp: Dichroic  
 Weight and Measurements including Packaging:  
 3 kg - 500 x 250 x 800 mm

Socle: Terre cuite rouge  
 Tige: Cuivre  
 Finition: Chrome  
 Particularité: Abat-jour en verre siliconé  
 Transformateur: Électronique inséré dans le socle  
 Ampoule: Dichroïque  
 Poids et mesures avec emballage:  
 3 kg - 500 x 250 x 800 mm

Base: Terracota roja  
 Tubo: Cobre  
 Acabado: Cromo  
 Particularidades: Cubrelámpara de cristal silicona  
 Transformador: Electrónico introducido en la base  
 Bombilla: Dicroica  
 Peso y medidas con embalaje:  
 3 kg - 500 x 250 x 800 mm

Cod. 5004

ECHIDNA

50W MAX | 2V Ø5 | GU5,3 230/12V

CE IP20

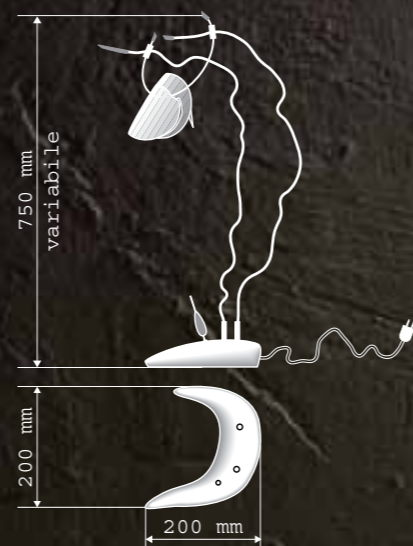

VOUS POUVEZ ONDULER LES TIGES COMME LA MER LES VAGUES.  
 SINUOSOS COMO LAS OLAS DEL MAR LOS TUBOS PUEDES PLASMAR.

SINUOSE COME LE ONDE DEL MARE GLI STELI PUDI PLASMARE.  
 YOU CAN SHAPE THE STEMS AS SINUOUS AS THE WAVES OF THE SEA.

ECHIDNA 17  
 LUCCHERO LUCCHERO





Base: Terracotta rossa  
 Stelo: Rame  
 Finitura: Cromo  
 Particolarità: Cavi teflon verdi coprilampada  
 vetro silicone  
 Trasformatore: Toroidale inserito nella base  
 Lampadina: Dicroica  
 Peso e misure con imballo:  
 3 kg - 200 x 200 x 660 mm



Base: Red terra-cotta  
 Stem: Copper  
 Finish: Chrome  
 Detail: Green teflon cables silicone-glass lampshade  
 Transformer: Toroidal within the base  
 Lamp: Dichroic  
 Weight and Measurements including Packaging:  
 3 kg - 200 x 200 x 660 mm

Socle: Terre cuite rouge  
 Pied: Cuivre  
 Finition: Chrome  
 Particularité: Câbles téflon verts, abat-jour en verre siliconé  
 Transformateur: Toroidal inséré dans le socle  
 Ampoule: Dichroïque  
 Poids et mesures avec emballage:  
 3 kg - 200 x 200 x 660 mm

Base: Terracota roja  
 Tubo: Cobre  
 Acabado: Cromo  
 Particularidades: Cables teflón verdes, cubrelámpara de cristal silicona  
 Transformador: Toroidal introducido en la base  
 Bombilla: Dicroica  
 Peso y medidas con embalaje:  
 3 kg - 200 x 200 x 660 mm

Cod. 5007

FLORIA

2 x 20W MAX 12V   
 ø35 GU4 230/12V 

CE IP20   

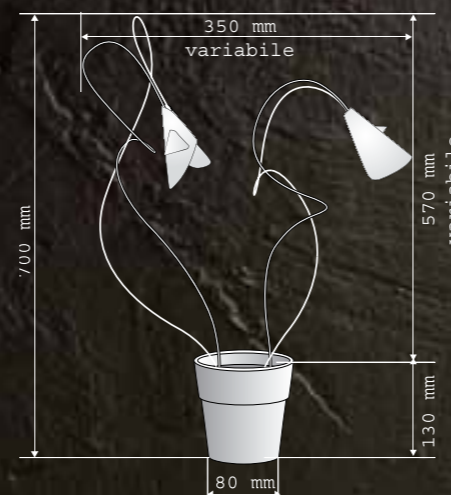

FLORIA 19  
 LUCCHERO PERO

JE NE SUIS NI UNE ROSE NI UNE TULIPE, JE SUIS FAITE COMME ÇA. ET ALORS?  
 NO SOY NI UNA ROSA NI UN TULIPÁN, SOY ASI. Y ENTONCES, ¿QUÉ?

NON SONO UNA ROSA NÈ UN TULIPANO, SONO FATTA COSÌ. E ALLORA?  
 I'M NEITHER A ROSE NOR A TULIP, I'M JUST LIKE THIS. SO WHAT?





Base: Ottone  
 Stelo: Rame  
 Finitura: Cromo  
 Particolarità: Tessuto in ottone nichelato  
 Trasformatore: Elettronico inserito nella base  
 Lampadina: Dicroica (blu)  
 Peso e misure con imballo:  
 5 kg - 1.130 x 450 x 260 mm

Base: Brass  
 Stem: Copper  
 Finish: Chrome  
 Detail: Nickel-plated brass tissue  
 Transformer: Electronic within the base  
 Lamp: Dichroic (blue)  
 Weight and Measurements including Packaging:  
 5 kg - 1.130 x 450 x 260 mm

Socle: Laiton  
 Pied: Cuivre  
 Finition: Chrome  
 Particularité: Tissu en laiton nickelé  
 Transformateur: Électronique inséré dans le socle  
 Ampoule: Dichroïque (bleue)  
 Poids et mesures avec emballage:  
 5 kg - 1.130 x 450 x 260 mm

Base: Laton  
 Tubo: Cobre  
 Acabado: Cromo  
 Particularidades: Tejido de latón niquelado  
 Transformador: Electrónico introducido en la base  
 Bombilla: Dicroica (azul)  
 Peso y medidas con embalaje:  
 5 kg - 1.130 x 450 x 260 mm

Cod. 5009

SHAKIRA

50W MAX | 2V Ø51  
 GU5,3 230/12V

CE IP20



SHAKIRA \_21

ELLE NE CHANTE PAS, ELLE NE DANSE PAS, MAIS ALLUMÉE ELLE VOUS FAIT RÊVER.  
 NO CANTA, NO BAILA, PERO ENCENDIDA TE HACE SOÑAR.

NON CANTA, NON BALLA, MA ACCESA TI FA SOGNARE.  
 IT DOESN'T SING, IT DOESN'T DANCE, BUT WHEN IT'S ON IT MAKES YOU DREAM.



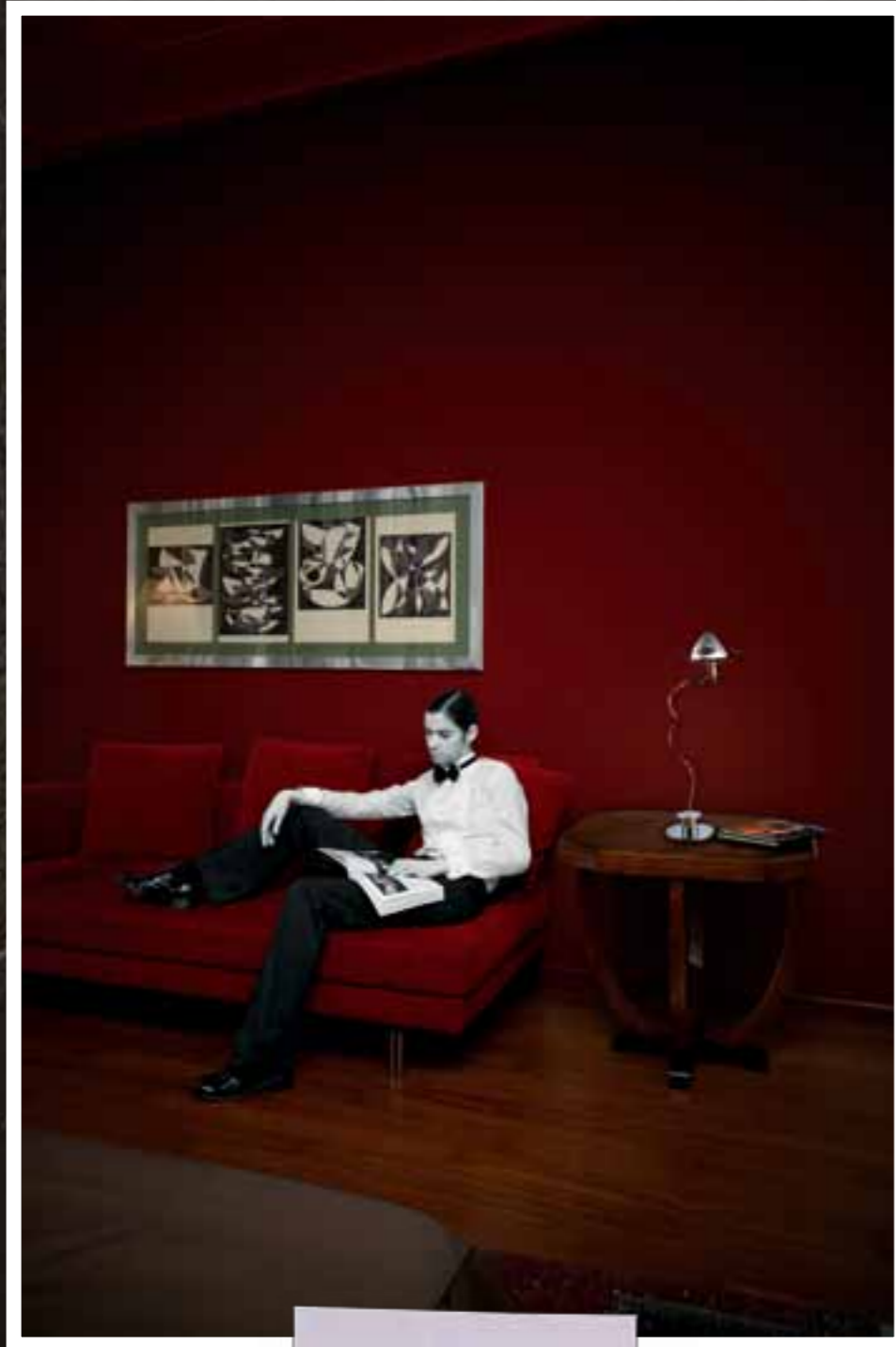

Cod. 5010

LUCIFERO

35W | 2V MAX  
GY6,35 230/12V

CE IP20



Base: Metallo  
Stelo: Rame  
Finitura: Cromo  
Particolarità: Alluminio graffiato Nome "Lucifero" illuminato in blu e rosso sul coprilampada  
Trasformatore: A spina  
Lampadina: Alogena bispina  
Peso e misure con imballo:  
5 kg - 500 x 250 x 800 mm

Base: Metal  
Stem: Copper  
Finish: Chrome  
Detail: Etched aluminium, the name "Lucifero" illuminated in blue and red on the lampshade  
Transformer: with Plug  
Lamp: Double plug-in Halogen  
Weight and Measurements including Packaging:  
5 kg - 500 x 250 x 800 mm

Socle: Métal  
Pied: Cuivre  
Finition: Chrome  
Particularité: Aluminium gratté, nom "Lucifero" illuminé bleu et rouge sur l'abat-jour  
Transformateur: À fiche  
Ampoule: Halogène bi-pin  
Poids et mesures avec emballage:  
5 kg - 500 x 250 x 800 mm

Base: Metal  
Tubo: Cobre  
Acabado: Cromo  
Particularidades: Aluminio rayado, Nombre "Lucifero" iluminado de azul y rojo en el cubrelámpara  
Transformador: De enchufe  
Bombilla: Halógena doble enchufe  
Peso y medidas con embalaje:  
5 kg - 500 x 250 x 800 mm



CONJUGAISON DU VERBE LUCIFÉRER.  
VOZ DEL VERBO LUCIFERAR.



VOCE DEL VERBO LUCIFERARE.  
PART OF THE VERB "TO LUCIFER", TO BRING LIGHT.

LUCIFERO 23





Cod. 6027

IL FRUTTO DEL PECCATO

40W (60W MAX)  
E14 230V



CE IP20



Base: Piatto in ceramica  
Stelo: Flessibile in ottone  
Finitura: Cromo  
Particolarità: Mela e forchetta sul piatto  
Lampadina: Colpo di vento  
Peso e misure con imballo:  
2,8 kg - 420 x 720 x 120 mm

Base: Ceramic plate  
Stem: Brass flexible stem  
Finish: Chrome  
Detail: Apple and fork on the plate  
Lamp: Gust of wind  
Weight and Measurements including Packaging:  
2,8 kg - 420 x 720 x 120 mm

Socle: Assiette en céramique  
Pied: Flexible en laiton  
Finition: Chrome  
Particularité: Pomme et fourchette sur l'assiette  
Ampoule: Coup de vent  
Poids et mesures avec emballage:  
2,8 kg - 420 x 720 x 120 mm

Base: Plato de cerámica  
Tubo: Flexible de latón  
Acabado: Cromo  
Particularidades: Manzana y tenedor en el plato  
Bombilla: Golpe de viento  
Peso y medidas con embalaje:  
2,8 kg - 420 x 720 x 120 mm

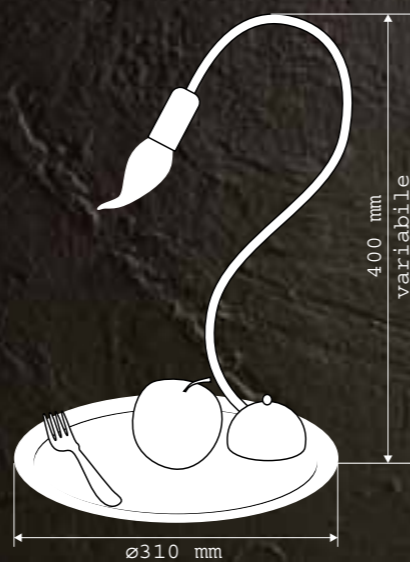

QUAND PÉCHER EST UN PLAISIR.  
CUANDO PECAR ES UN PLACER.



IL FRUTTO DEL PECCATO 25

QUANDO PECCARE È UN PIACERE.  
WHEN SIN IS A PLEASURE.

OSCAR DE LA PENA



# LUCIFERO A NEW YORK

Brooklyn Museum - New York



Chuck Close - Lucifero

## LUCIFERO SEDUCE LA GRANDE MELA

Da Torino alla Grande Mela. Le mille tentazioni di Lucifero conquistano New York: e se è difficile resistere al fascino misterioso di un Lucifero mitologico, come faranno i newyorkesi a non farsi incantare da mille forme di luce, originali e accattivanti? Per la prima volta, è il museo di arte contemporanea di Brooklyn, in occasione del BIFF (il Brooklyn International Film Festival), ad ospitare la collezione 2007 di Lucifero: d'ora in poi non stupiamoci se tra i strabilianti luccichii di Brooklyn, Manhattan, Central Park anche Lucifero avrà la sua parte.

## LUCIFERO SEDUCES THE BIG APPLE.

*From the city of Torino to the Big Apple. Lucifero's thousand temptations have conquered New York City: and even if it is difficult to resist the mysterious charm of the mythological Lucifer, how will New Yorkers be unable to be enchanted by the thousand light shapes, so original and captivating? For the first time, the Contemporary Art Museum in Brooklyn, in occasion of the Brooklyn International Film Festival, gave hospitality to the 2007 Lucifero collection: from now on we won't be surprised if among the dazzling lights of Brooklyn, Manhattan and Central Park, Lucifero has his say.*



Casa Privata  
Private House



Casa Privata  
Private House





LEO BURNETT  
sistema fuori catalogo per illuminare la scala del palazzo storico

LEO BURNETT  
Bespoke lighting system for the staircase of a historical mansion.



Cantine Cavagnero - La Morra - Cuneo  
Modello Tribal versione parete  
Cavagnero wine-producer La Morra - Cuneo  
Tribal model wall version



Applique - Versione speciale fuori catalogo  
Applique - Bespoke Special Version



Casa Privata  
Private House



Casa Privata  
Private House



Casa Privata  
Private House



Casa Privata  
Private House

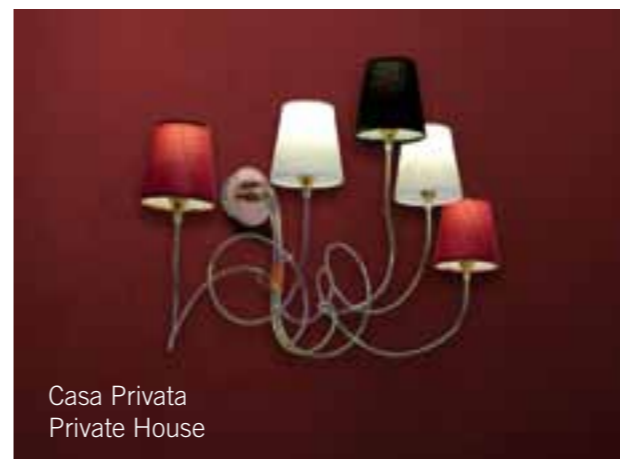

Casa Privata  
Private House



Casa Privata  
Private House





Casa Privata  
Private House



Studio Privata  
Private Studio



Casa Privata  
Private House



Casa Privata  
Private House



Casa Privata  
Private House





**Cod. 6047**

OPZIONI: (CR)

C A Y P

3x35W MAX  
GY6,35 12V  
220-240/12V

CE IP20

Base: Rame  
Opzione: Cromo cod. 6047 CR  
Particolarità: Steli in rame isolato e fogli in alluminio ramato da un lato  
Trasformatore: Elettronico inserito nella base  
Lampadina: Alogena bispina  
Peso e misure con imballo:  
2 kg - 250 x 410 x 500 mm

Base: Copper  
Options: Chrome code 6047CR  
Detail: Insulated copper stems and aluminium leaves on one side  
Transformer: Electronic within the base  
Bulb: Double plug-in halogen  
Weight and Measurements including Packaging:  
2 kg - 250 x 410 x 500 mm

Base: Cuivre  
Option: Chrome code 6047 CR  
Particularité: Tiges en cuivre isolé et feuilles en aluminium cuivré d'un côté  
Tranformateur: Électronique inséré dans le socle  
Ampoule: Halogène bi-pin  
Poids et mesures avec emballage:  
2 kg - 250 x 410 x 500 mm

Base: Cobre  
Opciones: Cromo cód. 6047 CR  
Particularidades: Tubos de cobre aislado y folios de aluminio cobrizo a un lado  
Transformador: Electrónico introducido en la base  
Bombilla: Halógena doble enchufe  
Peso y medidas con embalaje:  
2 kg - 250 x 410 x 500 mm

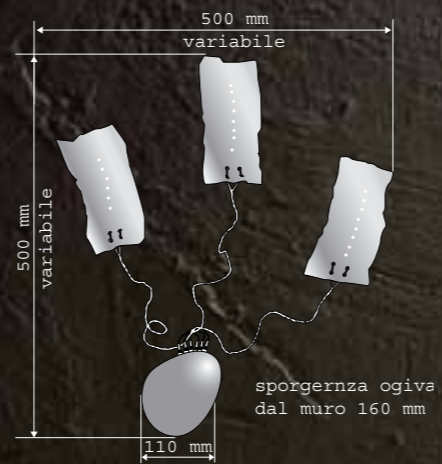

**OROLOGIO**  
**CAYP\_33**

LA CHALEUR DU CUIVRE POUR RETROUVER LA LUMIÈRE.  
EL CALOR DEL COBRE PARA VOLVER A ENCONTRAR LA LUZ DEL PASADO.

IL CALORE DEL RAME PER RITROVARE LA LUCE DEL PASSATO.  
THE WARMTH OF COPPER TO REDISCOVER LIGHT FROM THE PAST.





Cod. 6048

ARGENS

1 x 22W  
2GX13 FC 230V  
3 x 20W MAX  
G4 12V  
220-240/12V

CE IP20



Base: In metallo cromato  
Steli: Cromati  
Frontale: Plexiglas iridescente  
Particolarità: Occhi serigrafati all'interno  
Trasformatore e Alimentatore: Elettronici inseriti nella base  
Lampadine: Alogena bispina e Fluorescente  
Peso e misure con imballo:  
4,5 kg - 750 x 450 x 300 mm

Base: Chrome metal  
Stems: Chrome  
Front panel: Iridescent plexiglass  
Detail: Silk screen printed eyes on inside  
Transformer and power supply: Electronic within the base  
Bulb: Double plug-in halogen and fluorescent  
Weight and Measurements including Packaging:  
4,5 kg - 750 x 450 x 300 mm

Base: En métal chromé  
Tiges: Chromé  
Frontal: En plexiglas iridescent  
Particularité: Yeux sérigraphiés à l'intérieur  
Transformateur et alimentateur: Électronique insérés dans la base  
Ampoule: Halogène bi-pin et fluorescente  
Poids et mesures avec emballage:  
4,5 kg - 750 x 450 x 300 mm

Base: De metal cromado  
Tubos: Cromado  
Frontal: De plexiglas iridescente  
Particularidades: Ojos serigrafiados en el interior  
Transformador y Alimentador: Electrónico introducidos en la base  
Bombilla: Halógena doble enchufe y Fluorescente  
Peso y medidas con embalaje:  
4,5 kg - 750 x 450 x 300 mm



ARGENS\_35  
 LUCIFERO

COMBIEN DE VÉRITÉS SE CACHENT DERRIÈRE UN REGARD?  
¿CUÁNTAS VERDADES SE ESCONDEN DETRÁS DE UNA MIRADA?

QUANTE VERITÀ SI NASCONDONO DIETRO AD UNO SGUARDO?  
HOW MUCH TRUTH IS HIDDEN BEHIND A GLANCE?





Cod. 6049

CRUCIS

1 x 20W MAX  
G4 12V  
220-240/12V

CE IP20

Base: Metallo  
Finitura: Cromo  
Particolarità: Pendenti in cristallo  
Trasformatori: Elettronici inseriti nella base  
Lampadina: Alogena bispina  
Peso e misure con imballo:  
6 kg - 720 x 120 x 420 mm

Base: Metal  
Finish: Chrome  
Detail: Crystal pendants  
Transformers: Electronic within the base  
Bulb: Double plug-in halogen  
Weight and Measurements including Packaging:  
6 kg - 720 x 120 x 420 mm

Base: Métal  
Finition: Chrome  
Particularité: Pendants en cristal  
Transformateurs: électroniques insérés dans la base  
Ampoule: Halogène bi-pin  
Poids et mesures avec emballage:  
6 kg - 720 x 120 x 420 mm

Base: Metal  
Acabado: Cromo  
Particularidades: Colgantes de cristal  
Transformador y Alimentador: Electrónico introducidos en la base  
Bombilla: Halógena doble enchufe  
Peso y medidas con embalaje:  
6 kg - 720 x 120 x 420 mm

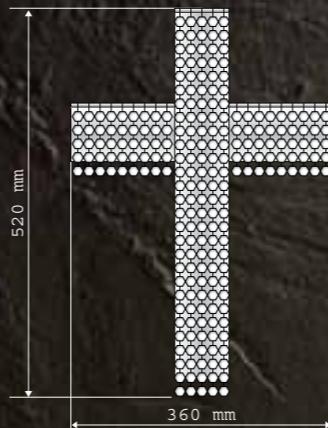

LA LUMIÈRE SE FAIT PRÉCIEUSE DANS L'ICÔNE PLUS EMBLÉMATIQUE.  
LA LUZ SE VUELVE PRECIOSA EN LA ICONA MÁS EMBLEMÁTICA.

LA LUCE SI FA PREZIOSA NELL'ICONA PIÙ EMBLEMATICA.  
LIGHT BECOMES MORE PRECIOUS WITHIN THE MOST EMBLEMIC ICON.

CRUCIS 37  
LUCIFERO





Cod. 6037

MASTIPHAL

1 x 60W MAX  
E27 230/12V



TAPE LED 7,2W



CE IP20



Base: Metallo  
Finitura: Cromo  
Mano: Resina  
Finitura: Metallizzata  
Particolarità: Bracciale di LED blu e silicone  
Trasformatore: Elettronico e Alimentatore LED inseriti nella base  
Lampadina: Goccia E27 12V  
Peso e misure con imballo:  
2,5 kg - 200 x 200 x 660 mm

Base: Metal  
Finish: Chrome  
Hand: Resin  
Hand finish: Metallized  
Detail: Blue LED silicone bracelet  
Transformer: Electronic within the base and LED power supply  
Bulb: E27 12V light bulb  
Weight and Measurements including Packaging:  
2,5 kg - 200 x 200 x 660 mm

Base: Métal  
Finition: Chrome  
Main: Résine  
Finition: Métallisée  
Particularité: Bracelet de LEDs bleu et silicone  
Transformateur: Électronique et alimentateur LEDs insérés dans la base  
Ampoule: Goutte E27 12V  
Poids et mesures avec emballage:  
2,5 kg - 200 x 200 x 660 mm

Base: Metal  
Acabado: Cromo  
Mano: Resina  
Acabado: Metalizada  
Particularidades: Anillo de LED azul y silicona  
Transformador: Electrónico y Alimentador LED introducidos en la base  
Bombilla: Gota E27 12V  
Peso y medidas con embalaje:  
2,5 kg - 200 x 200 x 660 mm



spessore 270 mm da parete

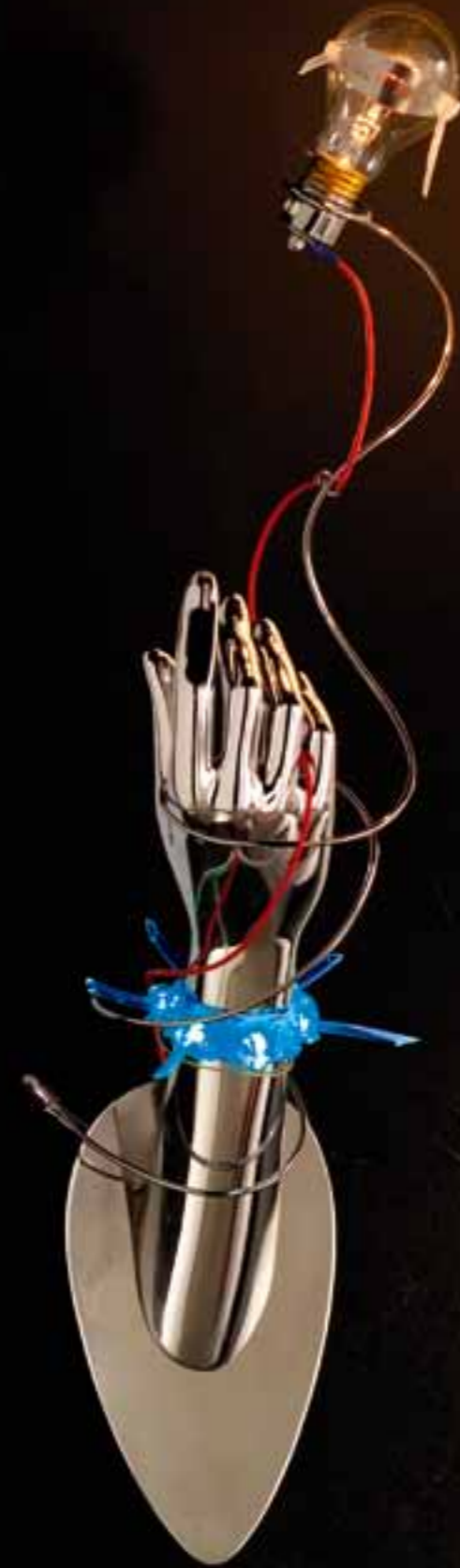

MASTIPHAL E39

LUCIFERO  
LUCIFERO  
LUCIFERO

TOUCHER LA LUMIÈRE AVEC UN DOIGT.  
TOCAR LA LUZ CON UN DEDO.

TOCCARE LA LUCE CON UN DITO.  
TO TOUCH THE LIGHT WITH ONE FINGER.





Base: Rame  
 Finitura: Cromo  
 Stelo: Flessibile cromato  
 Particolarità: Orientabile  
 Lampadina: Alogena  
 Peso e misure con imballo:  
 1kg - 112 x 290 x 400 mm

Base: Copper  
 Finish: Chrome  
 Stem: Chrome flexible stem  
 Detail: Revolving  
 Lamp: Halogen  
 Weight and Measurements including Packaging:  
 1kg - 112 x 290 x 400 mm

Base: Cuivre  
 Finition: Chrome  
 Tige: Flexible chromée  
 Particularité: Orientable  
 Ampoule: Halogène  
 Poids et mesures avec emballage:  
 1 kg - 112 x 290 x 400 mm

Base: Cobre  
 Acabado: Cromo  
 Tubo: Flexible cromado  
 Particularidades: Orientable  
 Bombilla: Halógena  
 Peso y medidas con embalaje:  
 1kg - 112 x 290 x 400 mm

Cod. 6035

FLINS

1 x 60W MAX  
 G9 230V



COURBES DOUCES POUR ATTEINDRE LA LUMIÈRE.  
 CURVAS SUAVES PARA ALCANZAR LA LUZ.

CURVE MORBIDE PER RAGGIUNGERE LA LUCE.  
 SMOOTH CURVES TO REACH THE LIGHT.





Base: Metallo  
 Finitura: Cromo  
 Particolarità: Riflettore orientabile  
 Lampadina: Alogena  
 Peso e misure con imballo:  
 0,7 kg - 210 x 150 x 200 mm

Base: Metal  
 Finish: Chrome  
 Detail: Revolving reflector  
 Lamp: Halogen  
 Weight and Measurements including Packaging:  
 0,7 kg - 210 x 150 x 200 mm

Base: Métal  
 Finition: Chrome  
 Particularité: Réflecteur orientable  
 Ampoule: Halogène  
 Poids et mesures avec emballage:  
 0,7 kg - 210 x 150 x 200 mm

Base: Metal  
 Acabado: Cromo  
 Particularidades: Reflector orientable  
 Bombilla: Halógena  
 Peso y medidas con embalaje:  
 0,7 kg - 210 x 150 x 200 mm

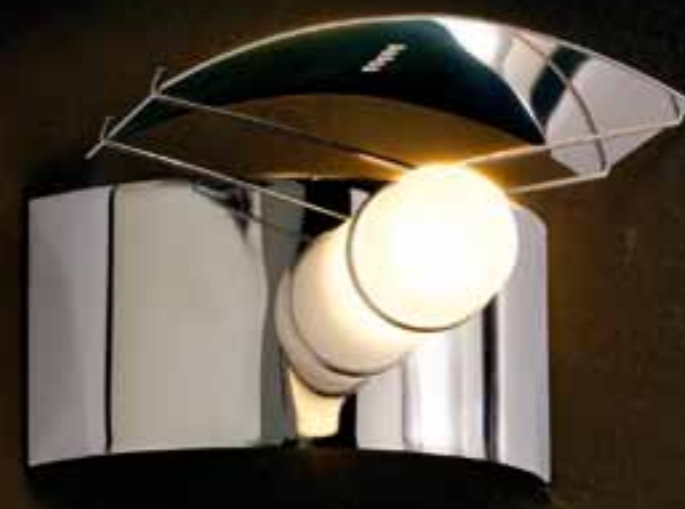

**Cod. 6042**

**MIREX**

1 x 60W MAX  
 G9 230V

CE IP20

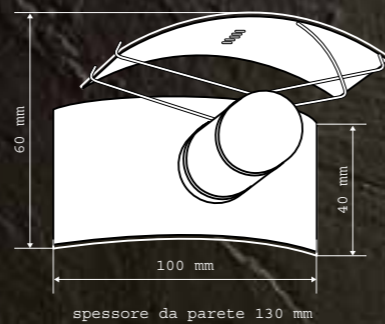

CLIC, LA TOUCHE QUI NOUS ILLUMINE.  
 CLICK: EL TOQUE QUE ILUMINA.

CLICK: IL TOCCO CHE CI ILLUMINA.  
 CLICK: A TOUCH BRINGING LIGHT TO US.

**MIREX** \_43

**OSPI**  
 QUALITÀ  
 SUPERIORE







**Cod. 6038 CR**

OPZIONI: (ZB) (ZG)

**DYSERS**

5 x 20W MAX BISPINA  
G4 230/12V

CE IP20   

Base: Metallo  
Stelo: Rame  
Finitura: Cromo (CR)  
Opzioni: Zincatura Bianca (ZB) Gialla (ZG)  
Particolarità: Steli Modellabili  
Trasformatore: Elettronico inserito nella base  
Lampadina: Alogena Bispina  
Peso e misure con imballo:  
1,8 kg - 112 x 290 x 400 mm

Base: Metal  
Stem: Copper  
Finish: Chrome (CR)  
Options: White (ZB) Yellow (ZG) galvanized  
Detail: Mouldable stems  
Transformer: Electronic within the base  
Lamp: double plug-in halogen  
Weight and Measurements including Packaging:  
1,8 kg - 112 x 290 x 400 mm

Base: Métal  
Tige: Cuivre  
Finition: Chrome (CR)  
Options: Zingage Blanc (ZB), Jaune (ZG)  
Particularité: Tiges modelables  
Transformateur: Électronique inséré dans la base  
Ampoule: Halogène bi-pin  
Poids et mesures avec emballage:  
1,8 kg - 112 x 290 x 400 mm

Base: Metal  
Tubo: Cobre  
Acabado: Cromo (CR)  
Opciones: Galvanizado con zinc en Blanco (ZB) y Amarillo (ZG)  
Particularidades: Tubos moldeables  
Transformador: Electrónico introducido en la base  
Bombilla: Halógena doble enchufe  
Peso y medidas con embalaje:  
1,8 kg - 112 x 290 x 400 mm

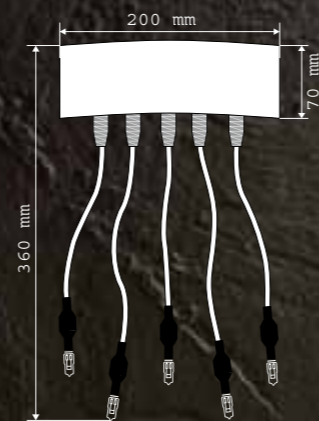

spessore 80 mm da parete



DYSERS \_45

WILKINFERO  
LUCIFERO

ELLES BOUGENT SOUS LE VENT COMME DES BRINS D'HERBE LUISANTS.  
SE MUEVEN AL VIENTO COMO LUCIENTES HILOS DE HIERBA.

SI MUOVONO AL VENTO COME LUCENTI FILI D'ERBA.  
THEY MOVE IN THE WIND LIKE SHINY BLADES OF GRASS.







**Cod. 6036 CR**

OPZIONI: (ZB) (ZG)

**FLAMEL**

7 x 20W MAX  
G4 230/12V

CE IP20   

Base: Metallo  
Finitura: Cromo (CR)  
Opzioni: Zincatura Bianca (ZB) Gialla (ZG)  
Stelo: Flessibile cromato  
Particolarità: Steli Modellabili  
Trasformatore: Elettronico inserito nella base  
Lampadina: Alogena Bispina  
Peso e misure con imballo:  
4 kg - 750 x 450 x 300 mm

Base: Metal  
Finish: Chrome (CR)  
Options: White (ZB) Yellow (ZG) galvanized  
Stem: Chrome flexible stem  
Detail: Mouldable stems  
Transformer: Electronic within the base  
Lamp: Double plug-in halogen  
Weight and Measurements including Packaging:  
4 kg - 750 x 450 x 300 mm

Base: Métal  
Finition: Chrome (CR)  
Options: Zingage Blanc (ZB), Jaune (ZG)  
Tiges: Flexible chromées  
Particularité: Tiges modelables  
Transformateur: Électronique inséré dans la base  
Ampoule: Halogène bi-pin  
Poids et mesures avec emballage:  
4 kg - 750 x 450 x 300 mm

Base: Metal  
Acabado: Cromo (CR)  
Opciones: Galvanizado con zinc en Blanco (ZB)  
Amarillo (ZG)  
Tubo: Flexible cromado  
Particularidades: Tubos Moldeables  
Transformador: Electrónico introducido en la base  
Bombilla: Halógena doble enchufe  
Peso y medidas con embalaje:  
4 kg - 750 x 450 x 300 mm

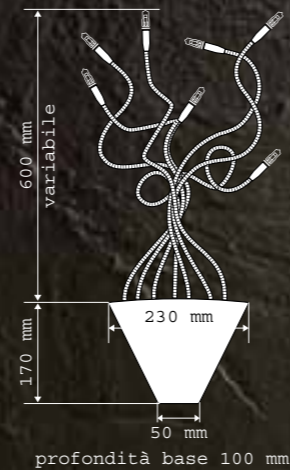

**FLAMEL 47**  
LUCIFERO

ENTRELAÇEMENT MAGIQUE DE MILLE PETITES FLAMMES.  
TRENZADO MÁGICO DE MIL LLAMAS.

INTRECCIO MAGICO DI MILLE FIAMMELLE.  
A MYSTERIOUS INTERLACE OF A THOUSAND FLAMES.





**Cod. 6043 CR**

OPZIONI: (ZB) (ZG)

QUIRIM

1 x 60W MAX  
G9 230V

CE IP20   

Base: Metallo  
Finitura: Cromo (CR)  
Opzioni: Zincatura Bianca (ZB) Gialla (ZG)  
Particolarità: Vetro pirex sabbiato  
Lampadina: Alogena  
Peso e misure con imballo:  
1 kg - 210 x 150 x 200 mm

Base: Metal  
Finish: Chrome (CR)  
Options: White (ZB) Yellow (ZG) galvanized  
Detail: Sandblasted pirex glass  
Lamp: Halogen  
Weight and Measurements including Packaging:  
1 kg - 210 x 150 x 200 mm

Base: Métal  
Finition: Chrome (CR)  
Options: Zingage blanc (ZB), jaune (ZG)  
Particularité: verre pyrex sablé  
Ampoule: Halogène  
Poids et mesures avec emballage:  
1 kg - 210 x 150 x 200 mm

Base: Metal  
Acabado: Cromo (CR)  
Opciones: Galvanizado con zinc en Blanco (ZB)  
Amarillo (ZG)  
Particularidades: Cristal pirex arenado  
Bombilla: Halógena  
Peso y medidas con embalaje:  
1 kg - 210 x 150 x 200 mm

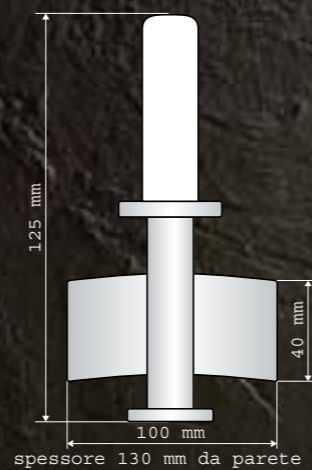

MONTRE-NOUS LE CHEMIN!  
MARCA NUESTRO CAMINO.

SEGNA IL NOSTRO CAMMINO.  
GUIDES OUR PATHS.

QUIRIM 49  
LUCIFERO  
LUCIFERO





Base: Metallo  
 Finitura: Cromo  
 Busto: Metacrilato  
 Particolarità: Busto trattato con speciali pellicole iridescenti e finitura siliconica  
 Lampadina: Alogena Bispina e Dicroica  
 Peso e misure con imballo:  
 4 kg - 250 x 410 x 500 mm

Base: Metal  
 Finish: Chrome  
 Female bust: Acrylic  
 Detail: Bust coated with unique iridescent films and silicone coating  
 Lamp: Double plug-in halogen, dichroic  
 Weight and Measurements including Packaging:  
 4 kg - 250 x 410 x 500 mm

Base: Métal  
 Finition: Chrome  
 Buste: Métacrylique  
 Particularité: Buste traité avec pellicules spéciales iridescentes et finition siliconée  
 Ampoule: Halogène bi-pin et dichroïque  
 Poids et mesures avec emballage:  
 4 kg - 250 x 410 x 500 mm

Base: Metal  
 Acabado: Cromo  
 Busto: Metacrilado  
 Particularidades: Busto tratado con especiales películas iridescentes y acabado con silicona  
 Bombilla: Halógena doble enchufe y Dicroica  
 Peso y medidas con embalaje:  
 4 kg - 250 x 410 x 500 mm

**Cod. 6034**

SOTTO IL VESTITO WALL

2 x 20W MAX  
 G4 BISPINA  
 230/1 2V



2 x 35W MAX  
 GU4 DICROICA Ø35  
 230/1 2V



CE IP20

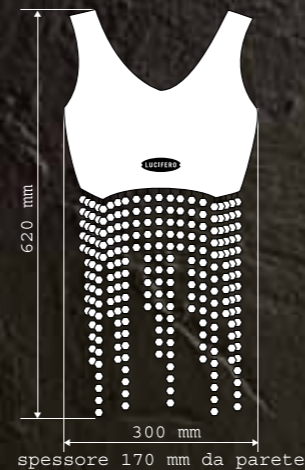

SOTTO IL VESTITO WALL 51

SENSUALITÉS ORIENTALES DANS LA LUEUR DE LA NUIT.  
 SENSUALIDADES ORIENTALES EN EL RESPLANDOR DE LA NOCHE.

SENSUALITÀ ORIENTALI NEL BAGLIORE DELLA NOTTE.  
 ORIENTAL SENSUALITY IN THE GLARE OF THE NIGHT.

LUCIFERO  
 LUCIFERO  
 LUCIFERO





Cod. 6033 WHITE  
Cod. 6032 BLACK

EXIT

7 x 20W MAX  
G4 230/12V

1 x 9W E14 230V  
RISPARMIO ENERGETICO  
ENERGY SAVING

CE IP20



Busto: Resina  
Steli: Cromati  
Finitura: Naturale e Nero  
Particolarità: Targa EXIT cromo, Retro illumina-  
to rosso  
Trasformatore: Elettronico inserito nella base  
Lampadina: Alogena e a Risparmio Energetico  
Peso e misure con imballo:  
5,2 kg - 260 x 1.130 x 450 mm

Base: Resin  
Stem: Chrome  
Finish: Natural and black  
Detail: Chrome plate "exit", rear red light  
Transformer: Electronic within the base  
Lamp: Halogen and energy saving  
Weight and Measurements including Packaging:  
5,2 kg - 260 x 1.130 x 450 mm

Buste: Résine  
Tiges: Chromé  
Finition: Naturelle et noir  
Particularité: Plaque exit chrome, arrière  
illuminé rouge  
Transformateur: Électronique inséré dans la base  
Ampoule: Halogène et à économie d'énergie  
Poids et mesures avec emballage:  
5,2 kg - 260 x 1.130 x 450 mm

Busto: Resina  
Tubos: Cromado  
Acabado: Natural y Negro  
Particularidades: Placa EXIT cromo, detrás  
iluminado rojo  
Transformador: Electrónico introducido en la base  
Bombilla: Halógena y de bajo consumo energético  
Peso e y medidas con embalaje:  
5,2 kg - 260 x 1.130 x 450 mm



SORTONS DES PRÉJUGÉS, UN NOUVEAU MONDE NOUS ATTEND.  
SALGAMOS DE LOS PREJUDICIOS, UN NUEVO MUNDO NOS ESPERA.

USCIAMO DAI PREGIUDIZI, UN NUOVO MONDO CI ATTENDE.  
THROW OUT PREJUDICES, A NEW WORLD AWAITS.

EXIT 53  
LUCIFERO





Cod. 6000

MORAX

71W MAX 12V  
GU5,3 230/12V Ø51

CE IP20



Base: Plexiglas  
Stelo: Cromato  
Particolarità: La sua trasparenza  
Trasformatore: Toroidale inserito nella base  
Lampadina: Dicroica  
Peso e misure con imballo:  
2,5 kg - 320 x 330 x 240 mm

Base: Plexiglas  
Stem: Chrome  
Detail: Its transparence  
Transformer: Toroidal within the base  
Lamp: Dichroic  
Weight and Measurements including Packaging:  
2,5 kg - 320 x 330 x 240 mm

Base: Plexiglas  
Tige: Chrome  
Particularité: Sa transparence  
Transformateur: Toroidal inséré dans la base  
Ampoule: Dichroïque  
Poids et mesures avec emballage:  
2,5 kg - 320 x 330 x 240 mm

Base: Plexiglas  
Tubo: Cromo  
Particularidades: Su transparencia  
Transformador: Toroidal introducido  
en la base  
Bombilla: Dicroica  
Peso y medidas con embalaje:  
2,5 kg - 320 x 330 x 240 mm

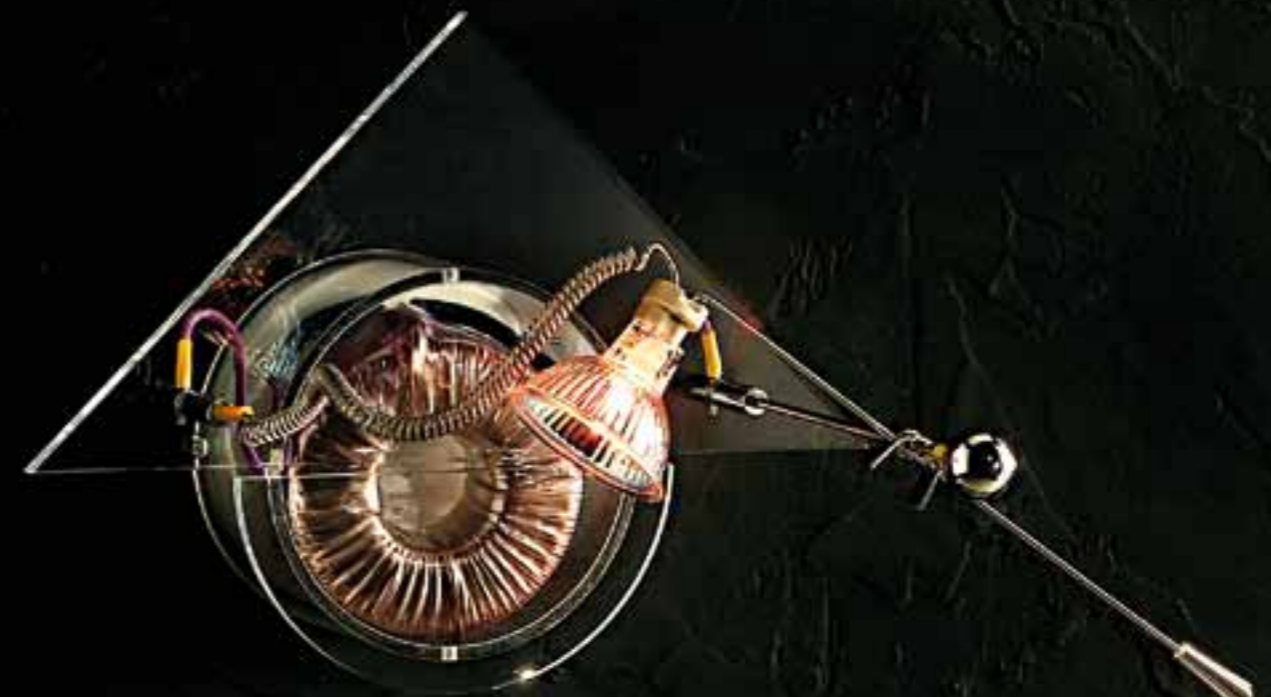
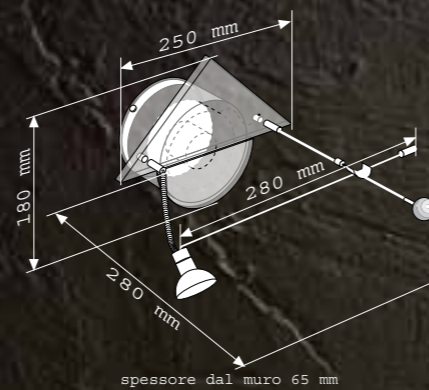

ELLE N'A RIEN À CACHER.  
NO TIENE NADA QUE ESCONDER.

NON HA NULLA DA NASCONDERE.  
THERE IS NOTHING TO HIDE.

MORAX \_55  
LUCIPIERO





Base: Metallo verniciato + specchio  
 Steli: Cromati  
 Particolarità: Specchio sulla base  
 Trasformatore: Toroidale inserito nella base  
 Lampadina: Dicroica  
 Peso e misure con imballo:  
 7 kg - 320 x 1.180 x 140 mm

Base: Painted Metal + Mirror  
 Stems: Chrome  
 Detail: Mirror on the base  
 Transformer: Toroidal within the base  
 Lamp: Dichroic  
 Weight and Measurements including Packaging:  
 7 kg - 320 x 1.180 x 140 mm

Base: Métal peint + miroir  
 Tiges: Chromées  
 Particularité: Miroir sur le socle  
 Transformateur: Toroidal inséré dans la base  
 Ampoule: Dichroïque  
 Poids et mesures avec emballage:  
 7 kg - 320 x 1.180 x 140 mm

Base: Metal Barnizado + espejo  
 Tubo: Cromo  
 Particularidades: Espejo en la base  
 Transformador: Toroidal introducido en la base  
 Bombilla: Dicroica  
 Peso y medidas con embalaje:  
 7 kg - 320 x 1.180 x 140 mm

**Cod. 6001 BIS**

NEXROTH

3 x 50W MAX 12V

ø51 GU5,3 230/12V



**Cod. 6001 TER**

NEXROTH

4 x 50W MAX 12V

ø51 GU5,3 230/12V



spessore dal muro 90 mm



NEXROTH 57

WALTER PIRELLA GÖTTSCHE LOWE

SUR LE MUR OU AU PLAFOND, L'OBSCURITÉ EST TRANSPERCÉE.  
 EN LAS PAREDES O EN EL TECHO LA OSCURIDAD ESTÁ HERIDA.

SULLA PARETE O SUL SOFFITTO IL BUIO È TRAFITTO.  
 DARKNESS IS PIERCED ON THE WALL OR ON THE CEILING.





Cod. 6011

YIN YANG

2 x 50W MAX | 2V  
GY6,35 230/12V

CE IP20



Base: Acciaio inox  
Stelo: rame cromato  
Finitura: (base) acciaio inox (Frontale) verniciato grigio  
Particolarità: Coprilampada in vetro silicone e cavi rosso e blu  
Trasformatore: Elettronico inserito nella base  
Lampadina: Alogena bispina  
Peso e misure con imballo:  
2,3 kg - 500 x 410 x 250 mm

Opzioni: Cavi trasparenti

Base: Stainless steel  
Stem: Chrome copper  
Finish: (base) stainless steel - (Front Panel) grey paint  
Detail: Silicone-glass lampshade, red and blue cables  
Transformer: Electronic within the base  
Lamp: Double plug-in halogen  
Weight and Measurements including Packaging:  
2,3 kg - 500 x 410 x 250 mm

Options: Transparent cables

Base: Acier inox  
Tige: Cuivre chromé  
Finition: (base) acier inox, (frontal) peint gris  
Particularité: Abat-jour en verre silicone, câbles rouges et bleus  
Transformateur: Électronique inséré dans la base  
Ampoule: Halogène bi-pin  
Poids et mesures avec emballage:  
2,3 kg - 500 x 410 x 250 mm

Opzioni: Câbles transparents

Base: Acero inox  
Tubo: Bronce Cromado  
Acabado: (base) acero inox, (frontal) Barnizado gris  
Particularidades: Cubrelámpara de cristal silico-na y cables rojo y azul  
Transformador: Electrónico introducido en la base  
Bombilla: Halógena doble enchufe  
Peso y medidas con embalaje:  
2,3 kg - 500 x 410 x 250 mm

Opciones: Cables transparentes

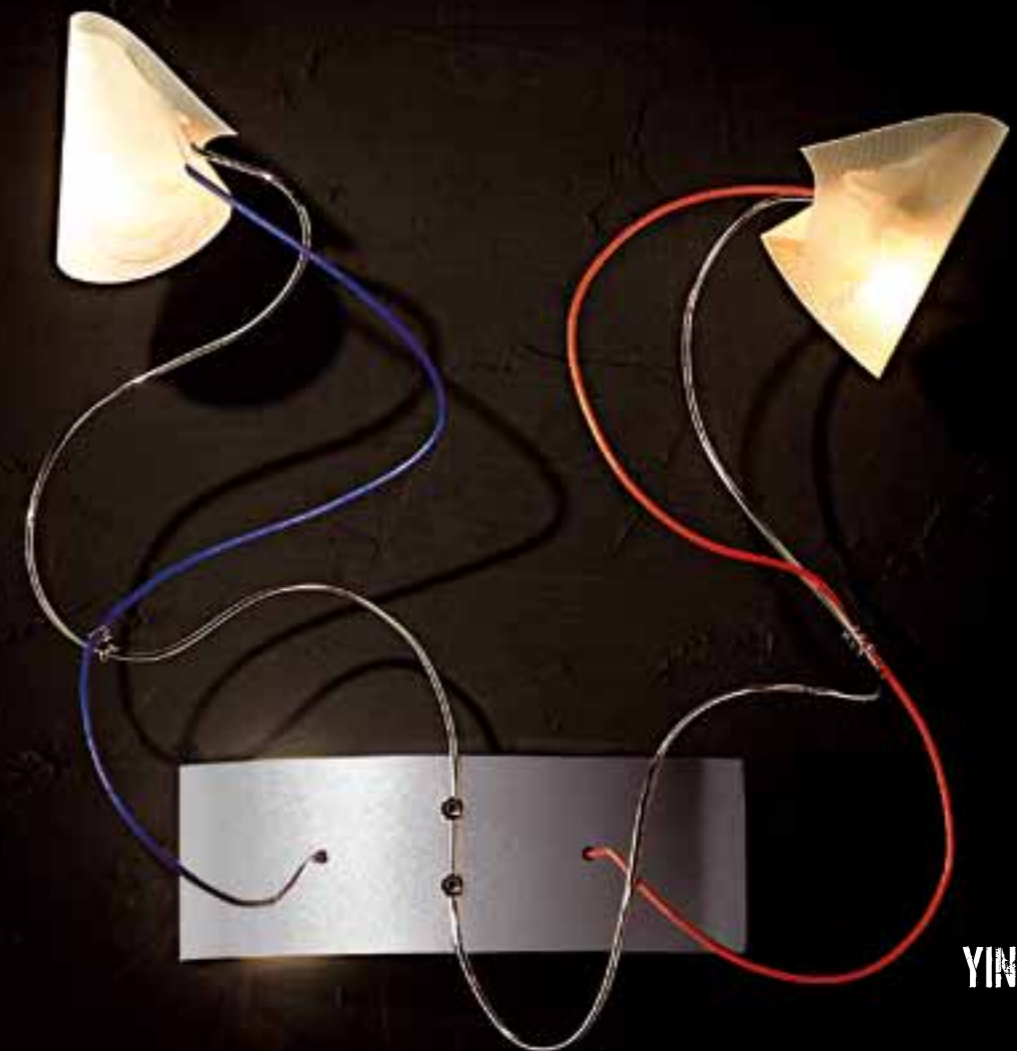
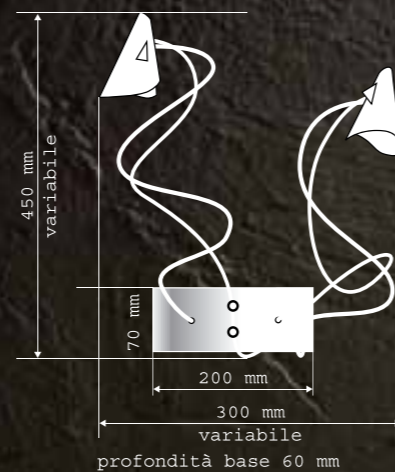

YIN YANG 59

ILS VONT BIEN ENSEMBLE.  
ESTÁN BIEN JUNTOS.

STANNO BENE INSIEME.  
THEY FIT TOGETHER.

LUCIFERO



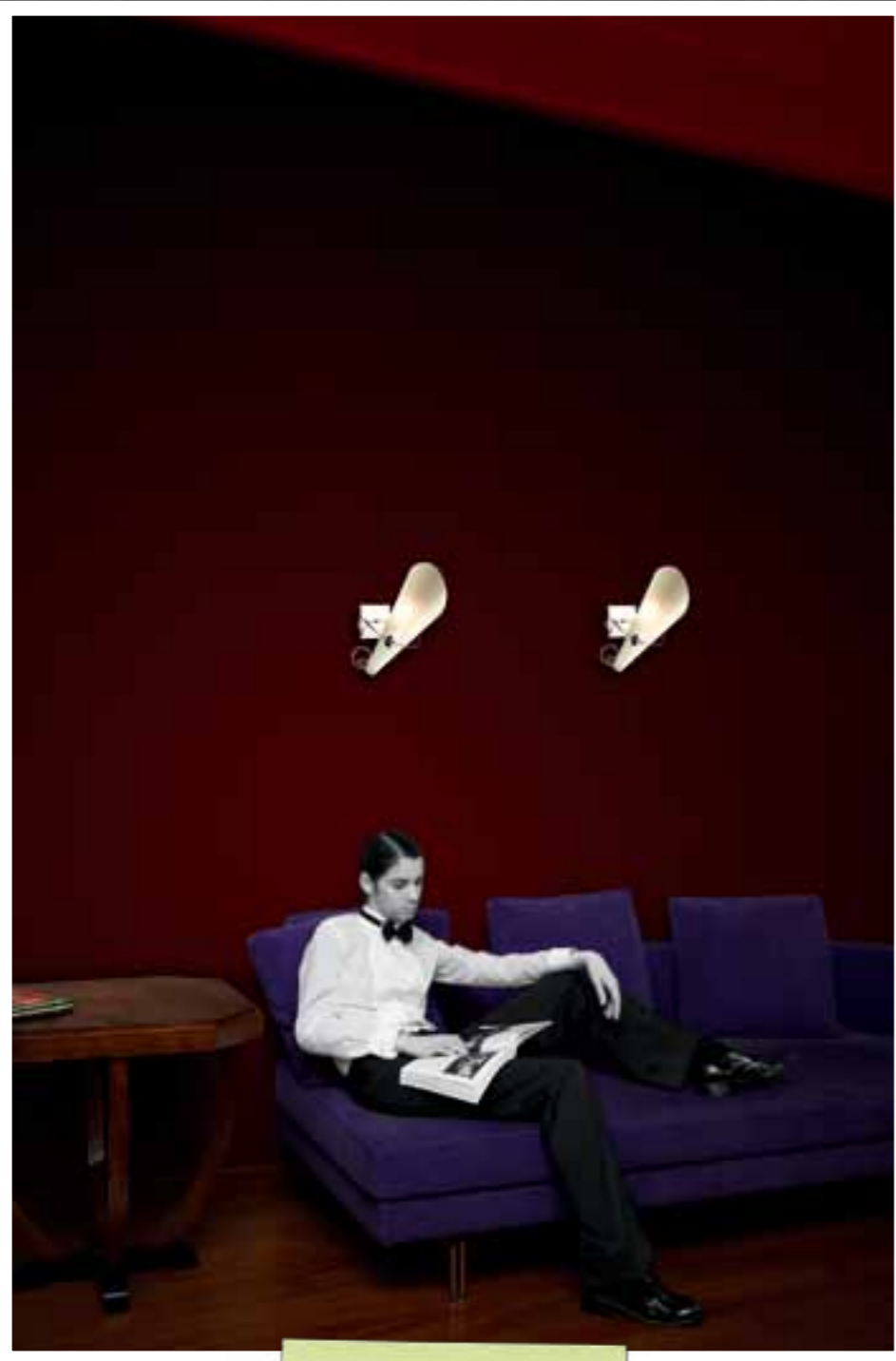



Cod. 6013

P U C K

100W MAX  
E27 HEG  
220-240V

CE IP20   

Base: Alluminio verniciato grigio  
Stelo: Cromato  
Particolarità: Coprilampada in vetro silicone  
Lampadina: Alogena doppio involucro  
Peso e misure con imballo:  
1,2 kg - 320 x 330 x 240 mm

Base: Gray paint aluminium  
Stem: Chrome  
Detail: Silicone-glass lampshade  
Lamp: Double wrapping halogen  
Weight and Measurements including Packaging:  
1,2 kg - 320 x 330 x 240 mm

Base: Aluminium peinte gris  
Tige: Chromé  
Particularité: Abat-jour en verre siliconé  
Ampoule: Halogène double enveloppe  
Poids et mesures avec emballage:  
1,2 kg - 320 x 330 x 240 mm

Base: Aluminio barnizado gris  
Tubo: Cromo  
Particularidades: Cubrelámpara de cristal silicona  
Bombilla: Halógena doble envoltura  
Peso y medidas con embalaje:  
1,2 kg - 320 x 330 x 240 mm

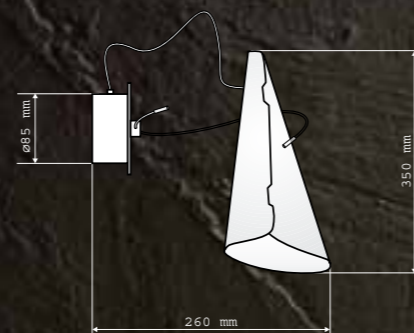

CLIC... UNE LUMIÈRE DOUCE ILLUMINE LA PIÈCE.  
CLICK... UNA SUAVE LUZ ILUMINA LA HABITACIÓN.

CLICK... UNA MORBIDA LUCE ILLUMINA LA STANZA.  
CLICK... A SOFT LIGHT LIGHTS UP THE ROOM.

PUCK\_61







Cod. 6015

ZOT APPLIQUE

150W MAX  
R7s 230V

CE IP20   

Base: Alluminio verniciato grigio  
Stelo: Cromato  
Particolarità: Cavi trasparenti e collare cromato  
Lampadina: Alogena lineare corta  
Peso e misure con imballo:  
1 kg - 400 x 290 x 112 mm

Base: Grey paint aluminium  
Stem: Chrome  
Detail: Transparent cables and chromium plated collar  
Lamp: Linear short halogen  
Weight and Measurements including Packaging:  
1 kg - 400 x 290 x 112 mm

Base: Aluminium peint gris  
Tige: Chrome  
Particularité: Câbles transparents et collier chromé  
Ampoule: Halogène linéaire courte  
Poids et mesures avec emballage:  
1 kg - 400 x 290 x 112 mm

Base: Aluminio barnizado gris  
Tubo: Cromo  
Particularidades: Cables transparentes y corona cromada  
Bombilla: Halógena lineal corta  
Peso y medidas con embalaje:  
1 kg - 400 x 290 x 112 mm

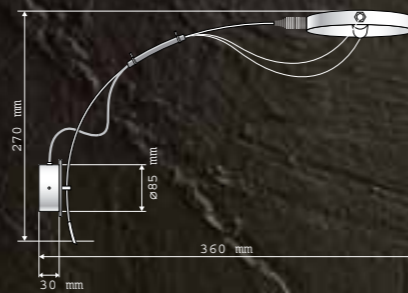

ZOT APPLIQUE \_63

LE MUR SE NOURRIT DE LUMIÈRE MAGIQUE.  
LA PARED SE NUTRE DE MÁGICA LUZ.

LA PARETE SI NUTRE DI MAGICA LUCE.  
THE WALL FEEDS ON THE MAGIC LIGHT.

DISEGNATO DA  
LUIGI PIRELLA





Base: Rame  
 Stelo: Rame  
 Finitura: Zincatura Gialla (ZG)  
 Opzioni: codice 6017 Cromo (CR) Zincatura Bianca (ZB), Verniciatura Bianca (VB), Nera (VN)  
 Opzione: codice 6016 Rame (RA)  
 Particolarità: Steli legati  
 Lampadina: Colpo di vento  
 Peso e misure con imballo:  
 2 kg - 200 x 200 x 660 mm

Base: Copper  
 Stem: Copper  
 Finish: Galvanized Yellow (ZG)  
 Options: code 6017 Chrome (CR) Galvanized White (ZB), White paint (VB), Black (VN)  
 Option: code 6016 Copper (RA)  
 Detail: Tied stems  
 Lamp: Gust of wind  
 Weight and Measurements including Packaging:  
 2 kg - 200 x 200 x 660 mm

Base: Cuivre  
 Tiges: Cuivre  
 Finition: Zingage Jaune (ZG)  
 Options: Code 6017 Chrome (CR), Zingage Blanc (ZB), Peinture Blanche (VB), Noire (VN)  
 Option: Code 6016 cuivre (RA)  
 Particularité: Tiges liées  
 Ampoule: Coup de vent  
 Poids et mesures avec emballage:  
 2 kg - 200 x 200 x 660 mm

Base: Cobre  
 Tubo: Cobre  
 Acabado: Galvanizado con Zinc en Amarillo (ZG)  
 Opciones: código 6017 Cromo (CR), Galvanizado con Zinc en Blanco (ZB), Barnizado Blanco (VB), Negro (VN)  
 Opciones: código 6016 Cobre (RA)  
 Particularidades: Tubos atados  
 Bombilla: Golpe de viento  
 Peso y medidas con embalaje:  
 2 kg - 200 x 200 x 660 mm



**Cod. 6017 ZG**  
 OPZIONI: (CR) (ZB) (VB) (VN)  
**ANEIS**  
 3 x 40W (60W MAX)  
 E14 230V  
 CE IP20  
**Cod. 6016 RA**

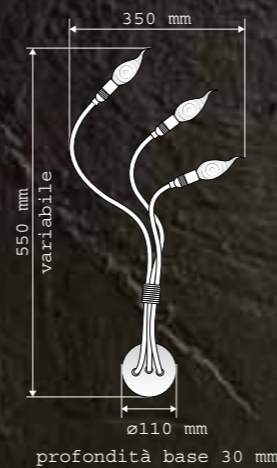

MYSTÉRIEUSE COMME UNE ANAGRAMME, ALLUMÉE ELLE DEVIENT TOUT UN PROGRAMME...  
 MISTERIOSA COMO UN ANAGRAMA CUANDO LA ENCIENDES ES TODO UN PROGRAMA...

MISTERIOSA COME UN ANAGRAMMA QUANDO L'ACCENDI È TUTTO UN PROGRAMMA...  
 AS MYSTERIOUS AS AN ANAGRAM, WHEN YOU SWITCH IT ON IT'S A SURPRISE...

ANEIS 65  
 ANAGRAMMA







**Cod. 6017 VB**

OPZIONI: (CR) (ZB) (ZG) (VN)

**A N E I S**

3 x 40W (60W MAX)  
E14 230V

CE IP20  

**Cod. 6016 RA**

Base: Rame  
Stelo: Rame  
Finitura: Verniciatura bianca (VB)  
Opzioni: codice 6017 Cromo (CR), Zincatura  
Bianca (ZB), Gialla (ZG)  
Opzione: codice 6016 Rame (RA)  
Particolarità: Steli legati  
Lampadina: Colpo di vento  
Peso e misure con imballo:  
2 kg - 200 x 200 x 660 mm

Base: Copper  
Stem: Copper  
Finish: White paint (VB)  
Options: code 6017 Chrome (CR), Galvanized  
White (ZB), Yellow (ZG), Black Paint (VN)  
Option: code 6016 Copper (RA)  
Detail: Tied stems  
Lamp: Gust of wind  
Weight and Measurements including Packaging:  
2 kg - 200 x 200 x 660 mm

Base: Cuivre  
Tiges: Cuivre  
Finition: Peinture Blanche (VB)  
Options: Code 6017 Chrome (CR), Zingage  
Blanc (ZB), Jaune (ZG) Peinture Noire (VN)  
Option: Code 6016 cuivre (RA)  
Particularité: Tiges liées  
Ampoule: Coup de vent  
Poids et mesures avec emballage:  
2 kg - 200 x 200 x 660 mm

Base: Cobre  
Tubo: Cobre  
Acabado: Barnizado Blanco (VB)  
Opciones: Código 6017 Cromo (CR), Galvani-  
zado con zinc en Blanco (ZB), Amarillo (ZG)  
Barnizado Negro (VN)  
Opciones: Código 6016 Cobre (RA)  
Particularidades: Tubos atados  
Bombilla: Golpe de viento  
Peso y medidas con embalaje:  
2 kg - 200 x 200 x 660 mm

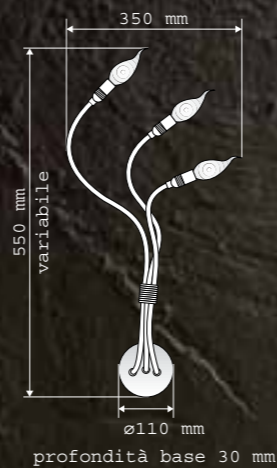

**ANEIS WHITE \_67**

TRIAD E DE MAGIE IRIDESCENTE.  
TRIAD E DE MAGIE IRIDESCENTE.

TRIADI DI MAGIA IRIDESCENTE.  
TRIADS OF IRIDESCENT CHARM.

**OSCAR PERINO**





Cod. 6016/5 RA

Cod. 6017/5 \*\*

OPZIONI: (CR) (ZB) (ZG) (VB) (VN)

A N E I S 5

5 x 40W (60W MAX)  
E14 230V

CE IP20



Base: Rame  
Stelo: Rame  
Finitura: Rame  
Opzioni: codice 6017/5 Cromo (CR) Zincatura  
Bianca (ZB) Gialla (ZG) Verniciatura Bianca  
(VB), Nera (VN)  
Particolarità: Steli legati  
Lampadina: Colpo di vento  
Peso e misure con imballo:  
3,7 kg - 750 x 450 x 300 mm

\*\* Opzione codice

Base: Copper  
Stem: Copper  
Finish: Copper  
Options: code 6017/5 Chrome (CR), Galvanized  
White (ZB), Yellow (ZG), White Paint (VB), Black (VN)  
Detail: Tied stems  
Lamp: Gust of wind

Weight and Measurements including Packaging:  
3,7 kg - 750 x 450 x 300 mm

\*\* Code Option

Base: Cuivre  
Tiges: Cuivre  
Finition: Cuivre  
Options: Code 6017/5 Chrome (CR), Zingage  
Blanc (ZB), Jaune (ZG), Peinture Blanche (VB),  
Noire (VN)  
Option: Code 6016 cuivre (RA)  
Particularité: Tiges liées  
Ampoule: Coup de vent  
Poids et mesures avec emballage:  
3,7 kg - 750 x 450 x 300 mm

\*\* Option code

Base: Cobre  
Tubo: Cobre  
Acabado: Cobre  
Opciones: Código 6017/5 Cromo (CR) Galva-  
nizado con zinc en Blanco (ZB) Amarillo (ZG)  
Barnizado Blanco (VB), Negro (VN)  
Particularidades: Tubos atados  
Bombilla: Golpe de viento  
Peso y medidas con embalaje:  
3,7 kg - 750 x 450 x 300 mm

\*\* Opciones código

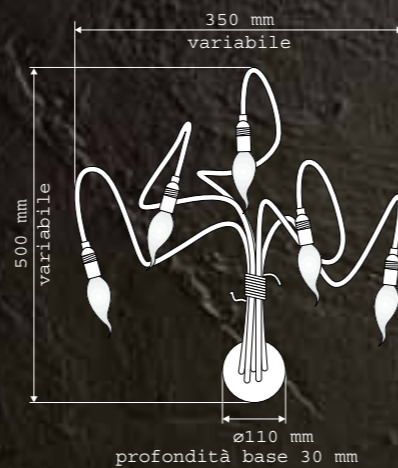

ANEIS 5 69

OBIETTIVO  
 QUALITÀ  
 SUPERIORE

... À 5 C'EST MIEUX.  
... CON 5 ES MEJOR

... A 5 È MEGLIO.  
... 5 IS BETTER.





Cod. 6018

N O X

10 x 10W MAX  
G4 230/12V

CE IP20



Base: Rame  
Stelo: Rame  
Finitura: Cromo  
Particolarità: Lampadine inserite nelle sfere  
Trasformatore: Toroidale inserito nella base  
Lampadina: Alogena bispina  
Peso e misure con imballo:  
2,6 kg - 200 x 200 x 660 mm

Base: Copper  
Stem: Copper  
Finish: Chrome  
Detail: Lamps in the spheres  
Transformer: Toroidal within the base  
Lamp: Double plug-in halogen  
Weight and Measurements including Packaging:  
2.6 kg - 200 x 200 x 660 mm

Base: Cuivre  
Tiges: Cuivre  
Finition: Chrome  
Particularité: Ampoules insérées dans les sphères  
Transformateur: Toroidal inséré dans la base  
Ampoule: Halogène bi-pin  
Poids et mesures avec emballage:  
2,6 kg - 200 x 200 x 660 mm

Base: Cobre  
Tubo: Cobre  
Acabado: Cromo  
Particularidades: Bombillas introducidas en las esferas  
Transformador: Toroidal introducido en la base  
Bombilla: Halógena doble enchufe  
Peso y medidas con embalaje:  
2,6 kg - 200 x 200 x 660 mm

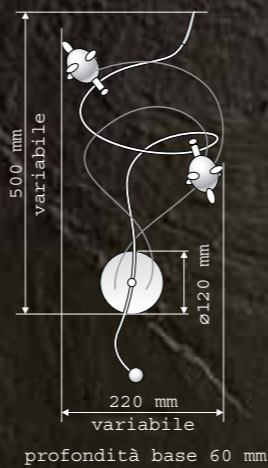

ET LES ÉTOILES OBSERVENT.  
Y LAS ESTRELLAS ESTÁN MIRANDO.

E LE STELLE STANNO A GUARDARE.  
THE STARS LOOK DOWN.

NOX\_71





Cod. 6019

F R E A

50W MAX Ø5 l  
GU5,3 230/12V

CE IP20



Base: Ottone  
Stelo: Rame  
Finitura: Cromo  
Particolarità: Coprilampada in vetro-silicone  
Trasformatore: Elettronico inserito nella base  
Lampadina: Dicroica  
Peso e misure con imballo:  
1,6 kg - 200 x 200 x 660 mm

Base: Brass  
Stem: Copper  
Finish: Chrome  
Detail: Silicone-glass  
lampshade  
Transformer: Electronic within the base  
Lamp: Dichroic  
Weight and Measurements including Packaging:  
1,6 kg - 200 x 200 x 660 mm

Base: Laiton  
Tiges: Cuivre  
Finition: Chrome  
Particularité: Abat-jour verre silicone  
Transformateur: Électronique inséré dans la base  
Ampoule: Dichroïque  
Poids et mesures avec emballage:  
1,6 kg - 200 x 200 x 660 mm

Base: Latón  
Tubo: Cobre  
Acabado: Cromo  
Particularidades: Cubrelámpara de cristal silicona  
Transformador: Electrónico introducido en la base  
Bombilla: Dicroica  
Peso y medidas con embalaje:  
1,6 kg - 200 x 200 x 660 mm

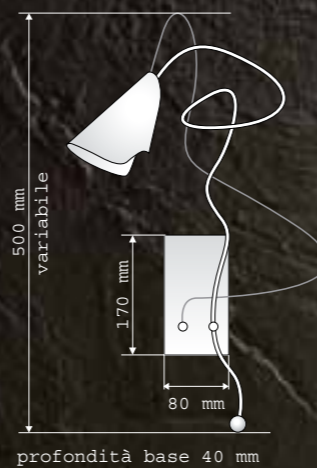

SUR LE MUR UNE LUMIÈRE ÉVOCATRICE.  
EN LA PARED UNA LUZ SUGESTIVA.

SULLA PARETE UNA SUGGESTIVA LUCE.  
ON THE WALL A ATMOSPHERIC LIGHT.

FREA \_73





Cod. 6020

AGABERTA

3 x 40W MAX  
E27 230/12V



CE IP20



Base: Acciaio inox  
Stelo: Rame  
Finitura: Cromo  
Particolarità: Cavi trasparenti e lampadine 12V  
Trasformatore: Elettronico inserito nella base  
Lampadina: Goccia E27 12V  
Peso e misure con imballo:  
2,8 kg - 500 x 410 x 250 mm

Base: Stainless steel  
Stem: Copper  
Finish: Chrome  
Detail: Transparent cables and 12 v lamps  
Transformer: Electronic within the base  
Bulb: E27 12V light bulb  
Weight and Measurements including Packaging:  
2,8 kg - 500 x 410 x 250 mm

Base: Acier inox  
Tiges: Cuivre  
Finition: Chrome  
Particularité: Câbles transparents et ampoules 12V  
Transformateur: Électronique inséré dans la base  
Ampoule: Goutte E27 12V  
Poids et mesures avec emballage:  
2,8 kg - 500 x 410 x 250 mm

Base: Acero inox  
Tubo: Cobre  
Acabado: Cromo  
Particularidades: Cables transparentes y bombillas 12V  
Transformador: Electrónico introducido en la base  
Bombilla: Gota E27 12V  
Peso y medidas con embalaje:  
2,8 kg - 500 x 410 x 250 mm



profondità base 70 mm



AGABERTA 75  
DISEGNO  
LUCIANO PERRO

COMME UNE FEMME CURIEUSE, ELLE VEUT Y VOIR CLAIR.  
COMO UNA MUJER CURIOSA QUIERE VERLO TODO CLARO.

COME UNA DONNA CURIOSA VUOLE VEDERCI CHIARO.  
LIKE AN INQUISITIVE WOMAN, IT WANTS TO SEE CLEARLY.





Base: Ottone  
 Stelo: Rame  
 Finitura: Cromo  
 Particolarità: Specchio e cavo rosso  
 Trasformatore: Elettronico inserito nella base  
 Lampadina: Goccia E27 12V  
 Peso e misure con imballo:  
 1,9 kg - 200 x 200 x 660 mm

Base: Brass  
 Stem: Copper  
 Finish: Chrome  
 Detail: Mirror and red cable  
 Transformer: Electronic within the base  
 Bulb: E27 12V light bulb  
 Weight and Measurements including Packaging:  
 1,9 kg - 200 x 200 x 660 mm

Base: Laiton  
 Tige: Cuivre  
 Finition: Chrome  
 Particularité: Miroir et câble rouge  
 Transformateur: Électronique inséré dans la base  
 Ampoule: Goutte E27 12V  
 Poids et mesures avec emballage:  
 1,9 kg - 200 x 200 x 660 mm

Base: Latón  
 Tubo: Cobre  
 Acabado: Cromo  
 Particularidades: Espejo y cable rojo  
 Transformador: Electrónico introducido en la base  
 Bombilla: Gota E27 12V  
 Peso y medidas con embalaje:  
 1,9 kg - 200 x 200 x 660 mm

Cod. 6021

NARCISO

1 x 60W MAX  
 E27 230/12V



CE IP20

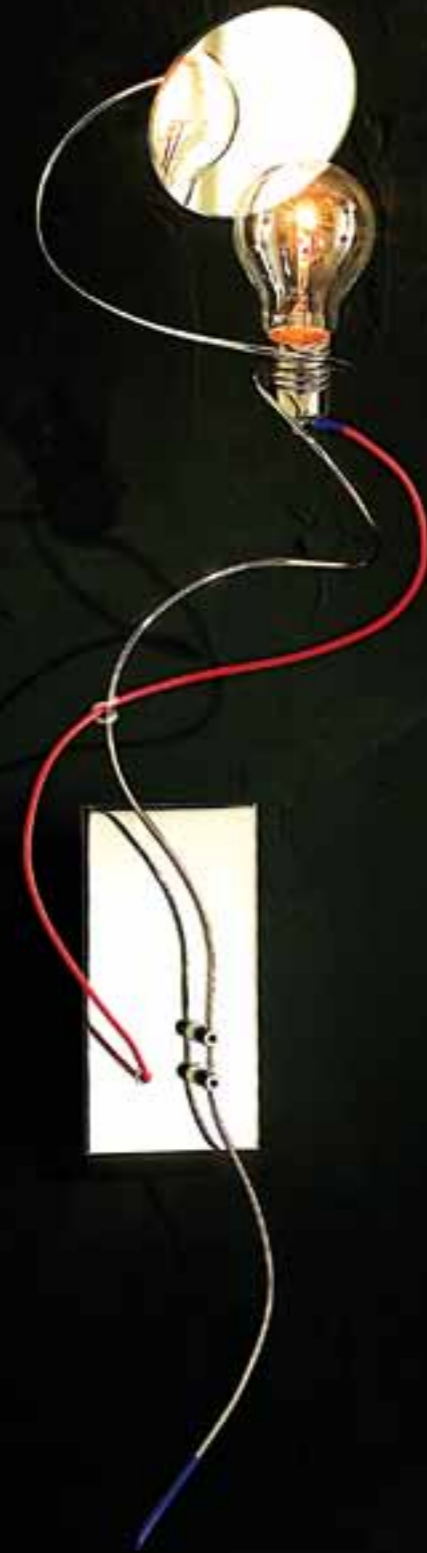
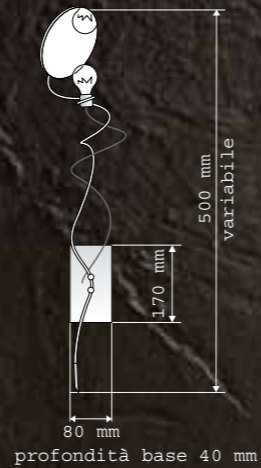

NARCISO 77

ELLE RÉFLÉCHIT SA VANITÉ EN ILLUMINANT LES OMBRES TIMIDES DU SOIR.  
 REFLEJA SU VANIDAD ILUMINANDO LAS TÍMIDAS SOMBRAS DE LA NOCHE.

RIFLETTE LA PROPRIA VANITÀ ILLUMINANDO LE TIMIDE OMBRE DELLA SERA.  
 REFLECTING ITS VANITY BY LIGHTING THE SHY EVENING SHADOWS.





Cod. 6023

THOR PAR

1 x 75W MAX  
E27 PAR 30 230V

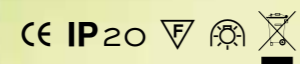

Base: Ottone  
Finitura: Cromo  
Particolarità: Versatilità  
Lampadina: Par 30  
Peso e misure con imballo:  
1,3 kg - 290 x 290 x 160 mm

Base: Brass  
Finish: Chrome  
Detail: Versatility  
Lamp: PAR 30  
Weight and Measurements including Packaging:  
1,3 kg - 290 x 290 x 160 mm

Base: Laiton  
Finition: Chrome  
Particularité: Éclectisme  
Ampoule: Par 30  
Poids et mesures avec emballage:  
1,3 kg - 290 x 290 x 160 mm

Base: Latón  
Acabado: Cromo  
Particularidades: Versatilidad  
Bombilla: Par 30  
Peso y medidas con embalaje:  
1,3 kg - 290 x 290 x 160 mm

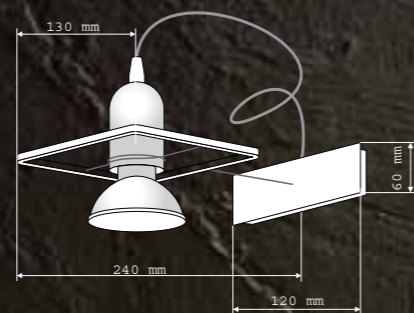

profondità base 30 mm



THOR PAR 79

ORIGINE ITALIANA

FIER, IL ILLUMINE LES ÉTOILES.  
ORGULLOSO ILLUMINA LAS ESTRELLAS.

FIERO ILLUMINA LE STELLE.  
PROUDLY LIGHTS THE STARS.





Base: Metallo spazzolato  
 Stelo: Rame  
 Finitura: Zincatura Gialla (ZG)  
 Opzioni: Cromo (CR), Zincatura Bianca (ZB)  
 Verniciatura Bianca (VB), Nera (VN)  
 Particolarità: Foglia di rame disco centrale e steli modellabili  
 Trasformatore: Elettronico inserito nella base  
 Lampadina: Alogena bispina  
 Peso e misure con imballo:  
 2,7 kg - 500 x 410 x 250 mm

Base: Brushed metal  
 Stem: Copper  
 Finish: Yellow galvanized (ZG)  
 Options: Chrome (CR), Galvanized White (ZB), White Paint (VB), Black (VN)  
 Detail: Copper-foil, central disk and mouldable stems  
 Transformer: Electronic within the base  
 Lamp: Double plug-in halogen  
 Weight and Measurements including Packaging:  
 2,7 kg - 500 x 410 x 250 mm

Base: Métal brossé  
 Tiges: Cuivre  
 Finition: Zingage Jaune (ZG)  
 Options: Chrome (CR), Zingage Blanc (ZB), Peinture Blanche (VB), Noire (VN)  
 Particularité: Feuille de cuivre disque central et tiges modelables  
 Transformateur: Électronique inséré dans la base  
 Ampoule: Halogène bi-pin  
 Poids et mesures avec emballage:  
 2,7 kg - 500 x 410 x 250 mm

Base: Metal cepillado  
 Tubo: Cobre  
 Acabado: Galvanizado con Zinc en Amarillo (ZG)  
 Opciones: Cromo (CR), Galvanizado con zinc en Blanco (ZB) Barnizado Blanco (VB), Negro (VN)  
 Particularidades: Hoja de cobre disco central y tubos moldeables  
 Transformador: Electrónico introducido en la base  
 Bombilla: Halógena doble enchufe  
 Peso y medidas con embalaje:  
 2,7 kg - 500 x 410 x 250 mm

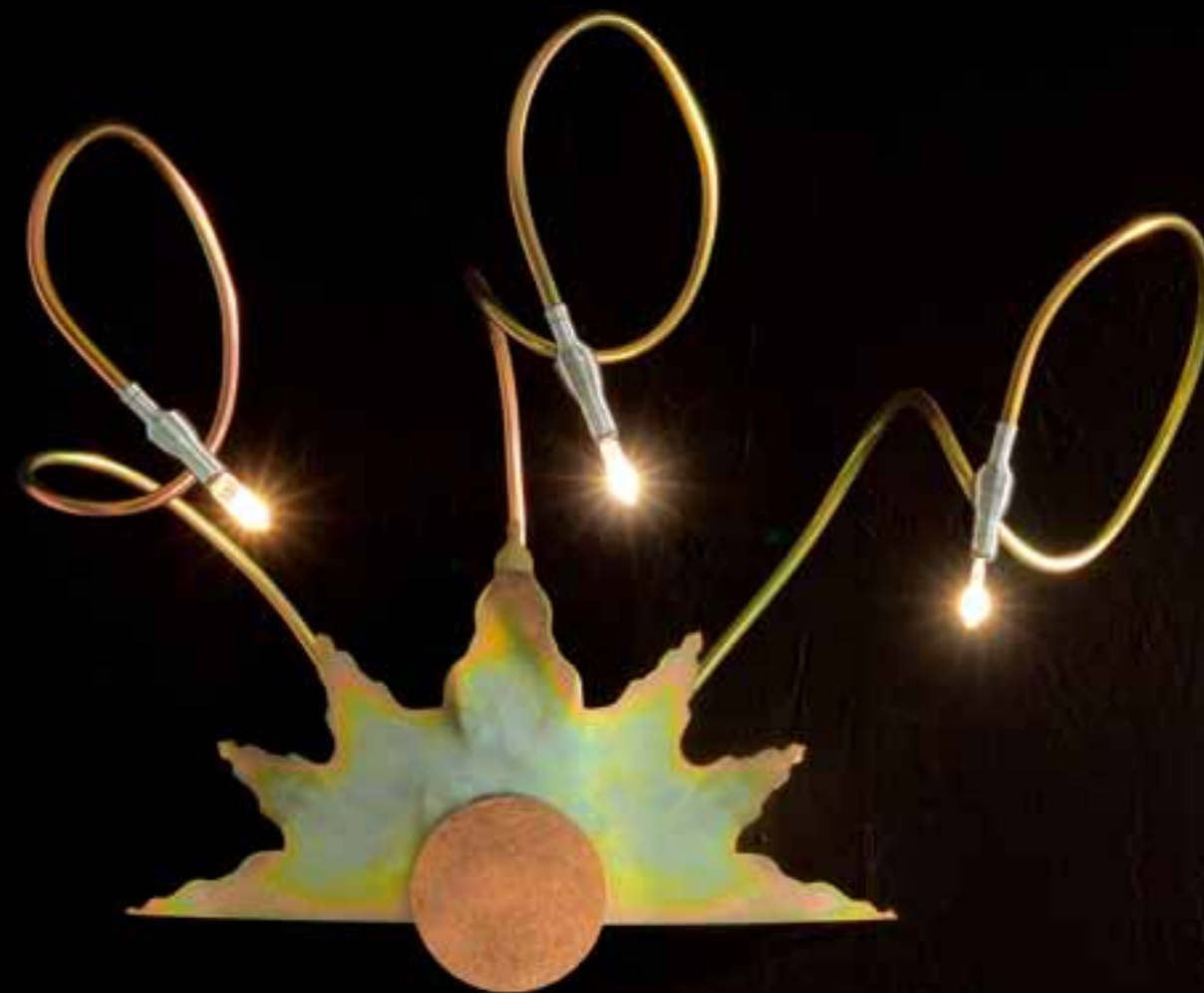

**Cod. 6028/3 ZG**  
 OPZIONI: (CR) (ZB) (VB) (VN)

**HALF FAAL**

3 x 20W MAX  
 G4 230/12V

CE IP20

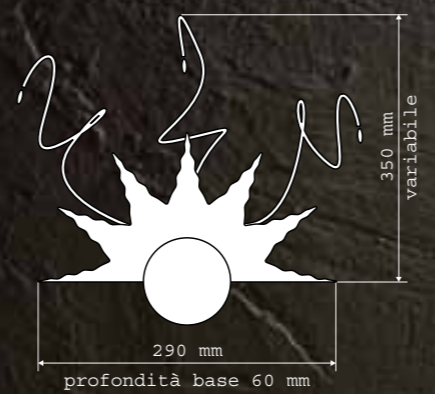

**HALF FAAL \_81**

**OSCAR PERINO**

SI TU NE MANQUÉS PAS D'IMAGINATION, FUYONS L'OBSCURITÉ...  
 SI NO TE FALTA LA FANTASÍA, ESCAPEMOS DE LA OSCURIDAD...

SE LA FANTASIA NON TI MANCA, ANDIAMO VIA DAL BUIO...  
 IF YOU ARE NOT WITHOUT IMAGINATION, LET'S LEAVE THE DARKNESS...







**Cod. 6028/5 VB**

OPZIONI (CR) (ZB) (ZG) (VN)

**HALF FAAL 5**

5 x 20W MAX  
G4 230/12V

CE IP20    

Base: Metallo  
Stelo: Rame  
Finitura: Verniciatura Bianca (VB),  
Opzioni: Cromo (CR), Zincatura Bianca (ZB),  
Gialla (ZG), Verniciatura Nera (VN)  
Particolarità: Disco centrale in foglia rame e  
steli modellabili  
Trasformatore: Elettronico inserito nella base  
Lampadina: Alogena bispina  
Peso e misure con imballo:  
3,6 kg - 250 x 410 x 500 mm

Base: Metal  
Stem: Copper  
Finish: White Paint (VB)  
Options: Chrome (CR), Galvanized White (ZB),  
Yellow (ZG), Black Paint (VN)  
Detail: Copper-foil, central disk and mouldable stems  
Transformer: Electronic within the base  
Lamp: Double plug-in halogen  
Weight and Measurements including Packaging:  
3,6 kg - 250 x 410 x 500 mm

Base: Métal  
Tiges: Cuivre  
Finition: Peinte Blanc (VB)  
Options: Chrome (CR), Zingage Blanc (ZB),  
Jaune (ZG), Peinture Noire (VN)  
Particularité: Feuille de cuivre disque central et  
tiges modelables  
Transformateur: Électronique inséré dans la base  
Ampoule: Halogène bi-pin  
Poids et mesures avec emballage:  
3,6 kg - 250 x 410 x 500 mm

Base: Metal  
Tubo: Cobre  
Acabado: Barnizada Blanco (VB)  
Opciones: Cromo (CR), Galvanizado con Zinc en  
Blanco (ZB) Amarillo (ZG), Barnizado Negro (VN)  
Particularidades: Hoja de cobre disco central y  
tubos moldeables  
Transformador: Electrónico introducido en la base  
Bombilla: Halógena doble enchufe  
Peso y medidas con embalaje:  
3,6 kg - 250 x 410 x 500 mm

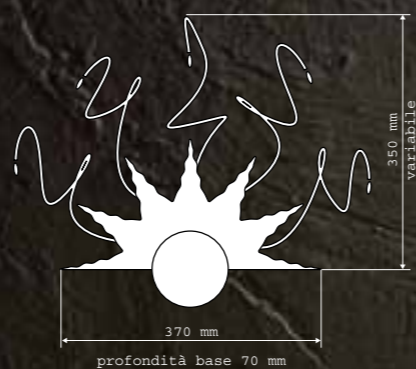

**HALF FAAL 5 WHITE \_83**

... SUIVEZ MON MYSTÈRE.  
... SIGUE MI MISTERIO.

... SEGUI IL MIO MISTERO.  
... FOLLOW MY MISTERY.

**LUCCIFERO**





Base: Metallo  
 Stelo: Rame cromato  
 Finitura: Cromo  
 Particolarità: Fogli serigrafati intercambiabili tramite calamita  
 Trasformatore: Elettronico inserito nella base  
 Lampadina: Goccia E27 12V  
 Peso e misure con imballo:  
 1,9 kg - 200 x 200 x 660 mm

Base: Metal  
 Stem: Chrome plated copper  
 Finish: Chrome  
 Détail: Interchangeable silk-screened sheets with magnet  
 Transformer: Electronic within the base  
 Bulb: E27 12V light bulb  
 Weight and Measurements including Packaging:  
 1,9 kg - 200 x 200 x 660 mm

Base: Métal  
 Tiges: Cuivre chromé  
 Finition: Chrome  
 Particularité: Feuilles sérigraphiées interchangeables avec aimant  
 Transformateur: Électronique inséré dans la base  
 Ampoule: Goutte E27 12V  
 Poids et mesures avec emballage:  
 1,9 kg - 200 x 200 x 660 mm

Base: Metal  
 Tubo: Cobre cromado  
 Acabado: Cromo  
 Particularidades: Folios serigrafiados intercambiables mediante imán  
 Transformador: Electrónico introducido en la base  
 Bombilla: Gota E27 12V  
 Peso y medidas con embalaje:  
 1,9 kg - 200 x 200 x 660 mm

Cod. 6029

NEQUAM

1 x 60W MAX  
 E27 230/12V



CE IP20

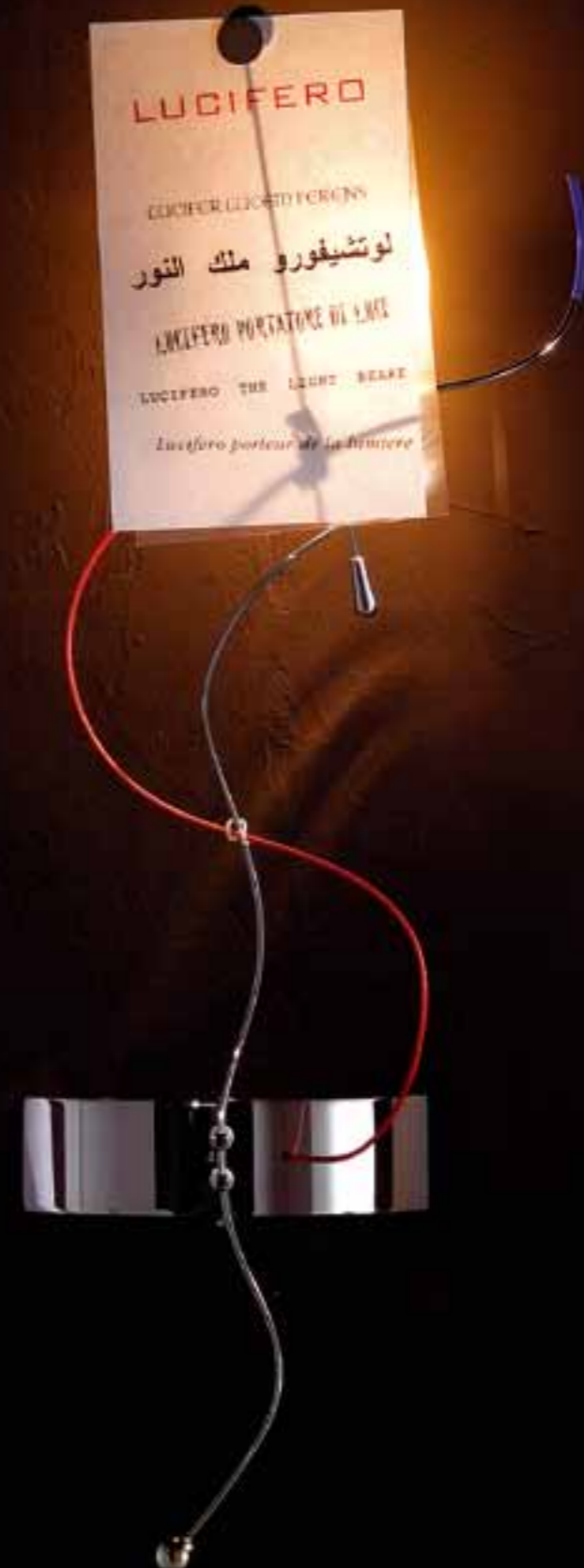
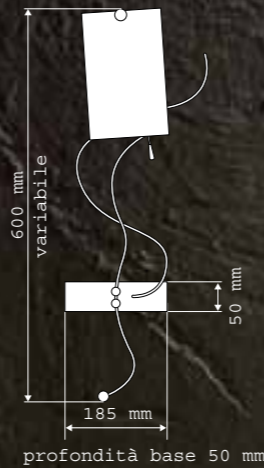

NEQUAM \_85

LUCIFERO

NE M'OUBLIEZ PAS!  
 NO TE OLVIDES DE MÍ.

NON TI SCORDAR DI ME.  
 FORGET-ME-NOT.





Cod. 6030 ZG

Cod. 6030 ZB

Z E U S F A B E R

3 x 20W MAX  
G4 230/12V

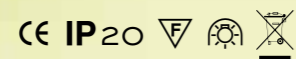

Base: Metallo spazzolato  
Stelo: Rame zincatura bianca  
Finitura: Zincatura gialla (ZG)  
Opzione: Zincatura bianca (ZB)  
Particolarità: Finitura siliconica sul pesce  
Trasformatore: Elettronico inserito nella base  
Lampadina: Alogena bispina  
Peso e misure con imballo:  
2,6 kg - 500 x 410 x 250 mm

Base: Brushed metal  
Stem: Copper white galvanized  
Finish: Yellow galvanized (ZG)  
Option: White galvanized (ZB)  
Detail: Silicone finish on the fish  
Transformer: Electronic within the base  
Lamp: Double plug-in halogen  
Weight and Measurements including Packaging:  
2,6 kg - 500 x 410 x 250 mm

Base: Métal brossé  
Tiges: Cuivre zingage blanc  
Finition: Zingage jaune (ZG)  
Option: Zingage blanc (ZB)  
Particularité: Finition siliconée sur le poisson  
Transformateur: Électronique inséré dans la base  
Ampoule: Halogène bi-pin  
Poids et mesures avec emballage:  
2,6 kg - 500 x 410 x 250 mm

Base: Metal cepillado  
Tubo: Cobre galvanizado con zinc en Blanco  
Acabado: Galvanizado con zinc en Amarillo (ZG)  
Opciones: Galvanizado con zinc en Blanco (ZB)  
Particularidades: Acabado con silicona en el pez  
Transformador: Electrónico introducido en la base  
Bombilla: Halógena doble enchufe  
Peso y medidas con embalaje:  
2,6 kg - 500 x 410 x 250 mm

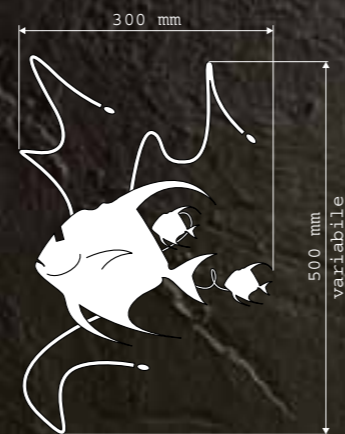

profondità base 120 mm



ZEUS FABER \_87

DISEGNO FABER

QUAND TU ES FATIGUÉ DE LA NUIT, PLONGE DANS LA MER (DANS LA LUMIÈRE DE MON FOND).  
CUANDO ESTÉS CANSADO DE LA NOCHE, TÍRATE A-MAR (EN LA LUZ DE MI FONDO DEL MAR).

QUANDO SEI STANCO DELLA NOTTE, TUFFATI A-MARE (NELLA LUCE DEL MIO FONDO).  
WHEN YOU ARE TIRED OF THE NIGHT, PLUNGE INTO THE SEA (IN THE LIGHT OF MY DEPTHS).





Lampadario Faal su misura  
per il ristorante Tenuta Marchesi di Barolo  
Barolo (CN) - italia

Bespoke chandelier Faal ,  
made for the restaurant  
"Tenuta Marchesi di Barolo" Barolo (Cuneo) - Italy



Case Private  
Private Houses







Theatre Politeama - Bra (CN) - Italy



Fuori Catalogo / Out of Catalogue

Lampadari 48 luci in rame zincato giallo, ø 3000 mm  
Chandeliers - 48 lights in copper yellow galvanized, ø 3000 mm



Villa Tiboldi



Gli architetti Genta e Bellonio, progettisti del teatro di Bra, durante una pausa relax.

The Designers of the Bra Theatre, Architects Genta and Bellonio taking a break.

Arch. Genta



Arch. Bellonio

Lampadario fuori catalogo costituito da 4 strutture indipendenti con possibilità di configurare sospensioni a diverse altezze.

Bespoke chandelier with 4 independent structures with the possibility to hang at different heights.



Lampadario fuori catalogo eseguito per il Teatro sociale della città di Alba - CN

Bespoke chandelier created for the "Teatro Sociale della Città di Alba" - (CN) - Italy



Istituto Culturale Italiano di Copenaghen  
Italian Cultural Institute of Copenaghen







L'arte è la massima espressione creativa e concettuale dell'uomo, egli lascia ai posteri testimonianza del proprio tempo e del proprio pensiero...

Lucifero con la luce testimonia la loro grandezza facendo omaggio a Salvador Dalì, Keith Haring, Marilyn Monroe, Antonio De Curtis e Andy Warhol.

Art is the best creative expression and conceptual tool belonging to man, it leaves to posterity testament of its own time and thought...

Lucifero through light pays homage to the greatness of Salvador Dalì, Keith Haring, Marilyn Monroe, Antonio De Curtis and Andy Warhol.

L'art est la plus grande expression créative et conceptuelle de l'homme, il transmet à la postérité le témoignage de son temps et de sa pensée...

Lucifero avec la lumière témoigne de leur grandeur rendant hommage à Salvador Dalì, Keith Haring, Marilyn Monroe, Antonio De Curtis et Andy Warhol

El arte es la máxima expresión creativa y conceptual del hombre, él deja testimoniancia a la posteridad del propio tiempo y del propio pensamiento...

Lucifero con la luz da testimonio de su grandezza homenajeando a Salvador Dalì, Keith Haring, Marilyn Monroe, Antonio De Curtis e Andy Warhol.







ANTONIO DE CURTIS



SALVADOR DALÌ



MARILYN MONROE



KEITH HARING



ANDY WARHOL







Cod. 7015 N  
Cod. 7015 B

A S H I K

150W MAX E27 HEG  
220-240V

CE IP20



Base: Metallo verniciato nero  
Paralume: Quash  
Opzione: cod. 7015 B  
Stelo: In rame all'interno di tubo in gomma,  
rivestito in tessuto  
Particolarità: Stelo modellabile  
Lampadina : Alogena  
Peso e misure con imballo:  
17 kg - 1.910 x 720 x 720 mm

Base: Black painted metal  
Shade: Quash  
Options: Code 7015 B  
Stem: Copper in a rubber tube, outer covering  
in fabric  
Detail: Malleable stem  
Bulb: Halogen  
Weight and Measurements including Packaging:  
17 kg - 1.910 x 720 x 720 mm

Socle: Métal peint noir  
Abat-jour: Quash  
Option: Code 7015 B  
Tige: En cuivre à l'intérieur d'un tube en caou-  
tchouc, revêtu de tissu  
Particularité: Tige modelable  
Ampoule: Halogène  
Poids et mesures avec emballage:  
17 kg - 1.910 x 720 x 720 mm

Base: Metal Barnizado Negro  
Pantalla: Quash  
Opciones: Cód. 7015 B  
Tubo: De cobre en el interior del tubo de goma,  
recubierto de tejido.  
Particularidades: Tubo moldeable  
Bombilla: Halógena  
Peso y medidas con embalaje:  
17 kg - 1.910 x 720 x 720 mm

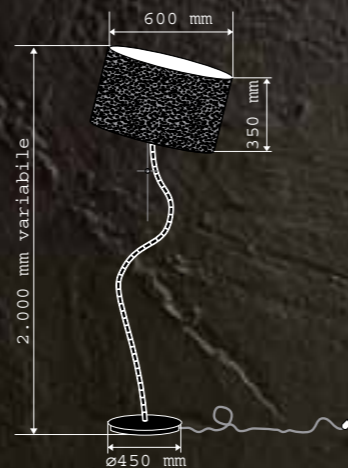

SINUEUX IL S'ÉLÈVE COMME LE PÉCHÉ ORIGINAL.  
SINUOSO SE ALZA COMO EL PECADO ORIGINAL.



SINUOSO SI INNALZA COME IL PECCATO ORIGINALE.  
IT RISES UP SINUOUSLY LIKE THE ORIGINAL SIN.

ASHIK\_97  
LUCHINERO





Cod. 7016

LEDOUX

PAR 30  
75W MAX E27  
220-240V



CE IP20



Accessori: Cromati  
Riflettore: Alluminio con specchio  
Particolarità: Posizionamento lampada attraverso cavi in rame stagnati, il posizionamento può assumere diverse inclinazioni e altezze. In dotazione 7 mt. di cavo rame stagnato.  
Lampadina: Par 30  
Peso e misure con imballo:  
3,7 kg - 250 x 410 x 500 mm

Fittings: Chrome  
Reflector: Aluminium with mirror  
Detail: Lamp positioned on copperplate cables, both slant and height can be altered. 7mt of Copperplate cable supplied.  
Bulb: Par 30  
Weight and Measurements including Packaging:  
3,7 kg - 250 x 410 x 500 mm

Accessoires: Chromés  
Réflecteur: Aluminium avec miroir  
Particularité: Positionnement lampe par câbles en cuivre zingué, le positionnement peut prendre différentes inclinaisons et hauteurs. En dotation 7m de câble cuivre zingué  
Ampoule: Par 30  
Poids et mesures avec emballage:  
3,7 kg - 250 x 410 x 500 mm

Accesorios: Cromados  
Reflector: Aluminio con espejo  
Particularidades: Colocación de la lámpara mediante cables de cobre estañados, la colocación puede asumir diferentes inclinaciones y alturas. En dotación 7 mt. de cable de cobre estañado.  
Bombilla: Par 30  
Peso y medidas con embalaje:  
3,7 kg - 250 x 410 x 500 mm



IMPÉTUEUX DANS L'ONDOIEMENT DU TEMPS.  
FLOTO EN EL COLUMPIO DEL TIEMPO.



FLUTTUA NELL'ALTELENA DEL TEMPO.  
FLUCTUATING ON THE SWING OF TIME.

LEDOUX 99  
LUCIFERO





**Cod. 7014 B**  
**Cod. 7014 N**

**N A X A C**

1 x 150W MAX E27 HEG  
220-240V  
TOUCH CONTROL  
LED RGB 7,2W 24V DC



CE IP20

Accessori: Metallo verniciato grigio  
Paralume: In policarbonato con effetto multi lente  
Cover: In tessuto Bianco (cod. 7014 B) Nero (cod. 7014 N)  
Particolarità: Lampada saliscendi, il LED RGB all'interno del paralume è touch. In dotazione 7 mt. di cavo in acciaio  
Lampada: Alogena  
Peso e misure con imballo:  
6,5 kg - 750 x 450 x 300 mm

Accessories: Grey painted metal  
Shade: Polycarbonate with multi lens effect  
Cover: White fabric (code 7014B) Black (code 7014N)  
Detail: Rise and fall lamp led rgb with touch switch inside the shade. 7mt of steel cable supplied.  
Bulb: Halogen  
Weight and Measurements including Packaging:  
6,5 kg - 750 x 450 x 300 mm

Accessoires: Métal peint gris  
Abat-jour: En polycarbonate avec effet grossissant  
Revêtement: En tissu blanc (code 7014 B) Noir (code 7014 N)  
Particularité: lampe réglable en hauteur LED RGB avec variateur d'intensité à l'intérieur de l'abat-jour. En dotation 7m de câble acier inox.  
Ampoule: Halogène  
Poids et mesures avec emballage:  
6,5 kg - 750 x 450 x 300 mm

Accesorios: Metal Barnizado gris  
Pantalla: De policarbonato con efecto multi-lente  
Cover: De tejido Blanco (cód. 7014 B) Negro (cód. 7014 N)  
Particularidades: Bombilla sube-baja led rgb en el interior de la pantalla è touch. En dotación 7 mt. de cable de acero inox.  
Bombilla: Halógena  
Peso y medidas con embalaje:  
6,5 kg - 750 x 450 x 300 mm

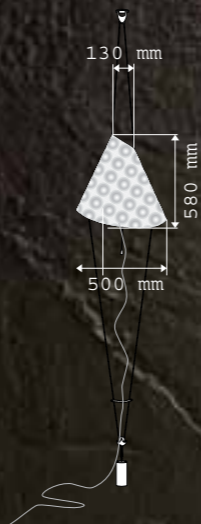

**NAXAC \_101**

LA VANITÉ EST TOUJOURS EN LUMIÈRE.  
LA VANIDAD ES SIEMPRE DE LUZ.

LA VANITÀ È SEMPRE IN LUCE.  
VANITY IS ALWAYS IN THE LIGHT.





Base: Metallo verniciato nero  
 Stelo: Telescopico in vetroresina  
 Paralume: Policarbonato  
 Particolarità: Vere sigarette finte  
 Lampadina: Colpo di vento  
 Peso e misure con imballo:  
 10 kg - 1.180 x 320 x 140 mm

Base: Black painted metal  
 Stem: Fibre glass, telescopic  
 Lampshade: Polycarbonate  
 Detail: Real artificial cigarettes  
 Lamp: Gust of wind  
 Weight and Measurements including Packaging:  
 10 kg - 1.180 x 320 x 140 mm

Socle: Métal peint noir  
 Pied: Téléscopique en fibres de verre  
 Abat-jour: Polycarbonate  
 Particularité: Vraies fausses cigarettes  
 Ampoule: Coup de vente  
 Poids et mesures avec emballage:  
 10 kg - 1.180 x 320 x 140 mm

Base: Metal Barnizado Negro  
 Tubo: Telescópico de resina cristal  
 Pantalla: Policarbonato  
 Particularidades: Verdaderos cigarrillos falsos  
 Bombilla: Golpe de viento  
 Peso y medidas con embalaje:  
 10 kg - 1.180 x 320 x 140 mm

Cod. 7013

NO SMOKING

3 x 60W MAX  
 E14 230V

CE IP20

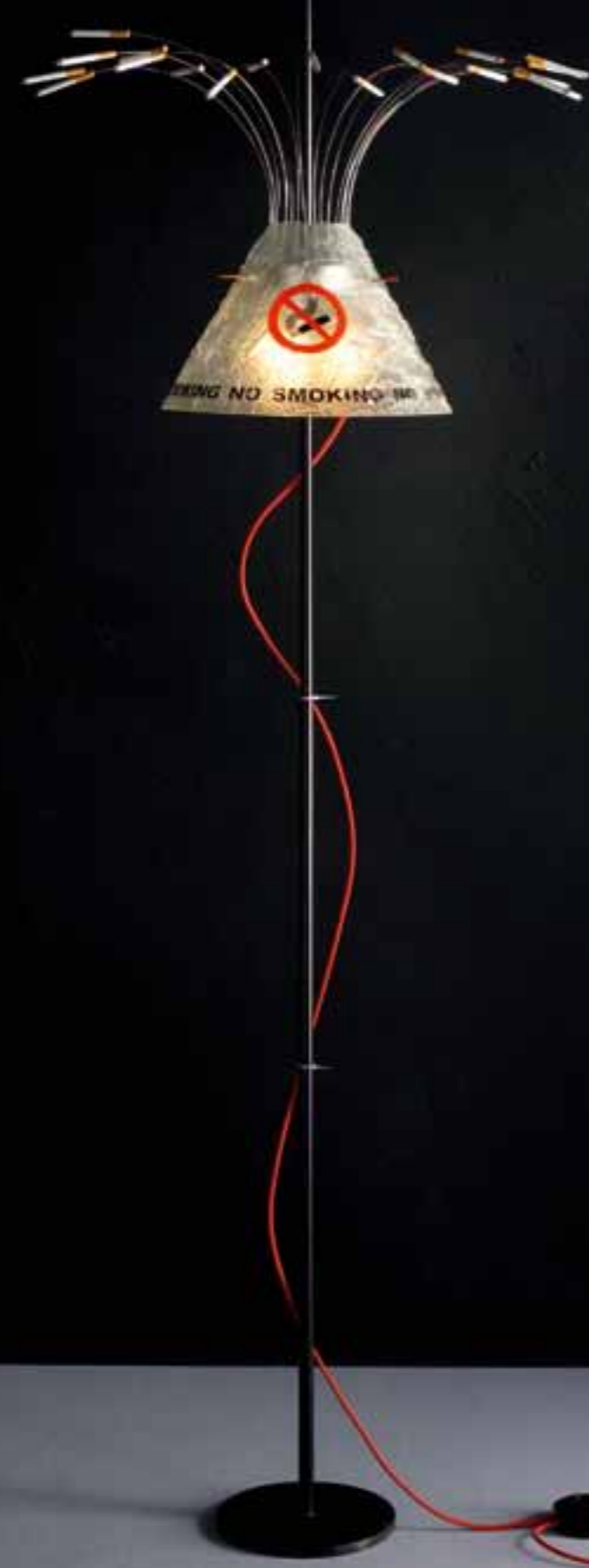
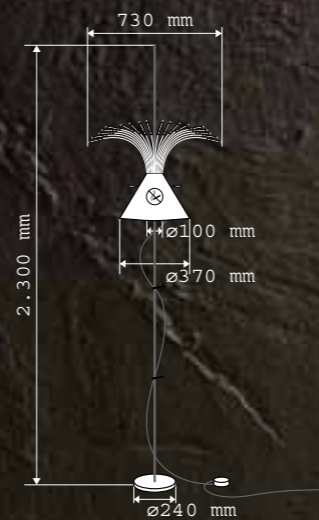

NO SMOKING \_103

D'ELIANTHINI

JOUER AVEC LES PROVOCATIONS DE L'ART.  
 JUGAR CON LAS PROVOCACIONES DEL ARTE.

GIOCARE CON LE PROVOCAZIONI DELL'ARTE.  
 PLAYING WITH ART OF PROVOCATION.





Base: Rame  
Stelo: Rame  
Finitura: Rame (RA)  
Opzioni: Cromata (CR), Zincatura Bianca (ZB),  
Gialla (ZG) Verniciatura Bianca (VB), Nera (VN)  
Particolarità: Steli legati  
Lampadina: Colpo di vento  
Peso e misure con imballo:  
9,5 kg - 360 x 300 x 2.150 mm

Opzione: Con più steli (max 9)

Base: Copper  
Stem: Copper  
Finish: Copper  
Options: Chrome (CR) Galvanized White (ZB)  
Yellow (ZG), White Paint (VB), Black (VN)  
Detail: tied stems  
Lamp: Gust of wind  
Weight and Measurements including Packaging:  
9,5 kg - 360 x 300 x 2.150 mm

Option: With more stems (9 max)

Socle: Cuivre  
Tiges: Cuivre  
Finition: Cuivre (RA)  
Options: Chromée (CR), Zingage Blanc (ZB),  
Jaune (ZG), Peinture Blanche (VB), Noire (VN)  
Particularité: Tiges liées  
Ampoule: Coup de vent  
Poids et mesures avec emballage:  
9,5 kg - 360 x 300 x 2.150 mm

Option: Avec plusieurs tiges (max 9)

Base: Cobre  
Tubo: Cobre  
Acabado: Cobre (RA)  
Opciones: Cromada (CR), Galvanizado con Zinc  
en Blanco (ZB), Amarillo (ZG) Barnizado Blanco  
(VB), Negro (VN)  
Particularidades: Tubos atados  
Bombilla: Golpe de viento  
Peso y medidas con embalaje:  
9,5 kg - 360 x 300 x 2.150 mm

Opciones: Con más tubos (máx 9)

**Cod. 7003**  
OPZIONI: (CR) (ZB) (ZG) (VB) (VN)

**TRIBAL**

3 x 40W (60W MAX)  
E14 230V

CE IP20



**TRIBAL \_105**  
DUE  
TRE  
QUATTRO  
CINQUE  
SEI  
SETTE  
OTTO  
NINE  
DIECI

UN.. DEUX.. TROIS.. C'EST LE NOMBRE PARFAIT POUR ACCORDER L'OBSCURITÉ AVEC LA LUMIÈRE.  
UNO... DOS... TRES... ES EL NÚMERO PERFECTO PARA PONER DE ACUERDO LA OSCURIDAD CON LA LUZ.

UNO... DUE... TRE... È IL NUMERO PERFETTO PER METTERE D'ACCORDO IL BUIO CON LA LUCE.  
ONE... TWO... THREE... IT'S THE PERFECT NUMBER TO MAKE THE DARK AGREE WITH THE LIGHT.





**Cod. 7008 CR**

OPZIONI: (RA) (ZB) (ZG) (VB) (VN)

VILLA RIVOLI

12 x 40W MAX  
E14 230V



CE IP20



Base: Metallo zincato  
Stelo: Rame  
Finitura: Cromo (CR)  
Opzioni: Rame (RA), Zincatura Bianca (ZB),  
Gialla (ZG), Verniciatura Bianca (VB), Nera (VN)  
Particolarità: Foglia argento sulla base solo nella  
versione Cromo (CR)  
Lampadina: Colpo di vento  
Peso e misure con imballo:  
19 kg - 570 x 550 x 2.300 mm

Base: Galvanized metal  
Stem: Copper  
Finish: Chrome  
Options: Copper (RA), Galvanized White (ZB),  
Yellow (ZG), White Paint (VB), Black (VN)  
Detail: Silver leaf on base only on Chrome (CR) version  
Lamp: Gust of wind  
Weight and Measurements including Packaging:  
19 kg - 570 x 550 x 2.300 mm

Socle: Métal zingué  
Tiges: Cuivre  
Finition: Chrome (CR)  
Options: Cuivre (RA), Zingage Blanc (ZB), Jau-  
ne (ZG), Peinture Blanche (VB), Noire (VN)  
Particularité: Feuille argent sur le socle pour la  
version Chrome (CR) seulement  
Ampoule: Coup de vent  
Poids et mesures avec emballage:  
19 kg - 570 x 550 x 2.300 mm

Base: Metal Galvanizado con Zinc  
Tubo: Cobre  
Acabado: Cromo (CR)  
Opciones: Cobre (RA), Galvanizado con zinc en  
Blanco (ZB), Amarillo (zg), Barnizado Blanco  
(VB), Negro (VN)  
Particularidades: Hoja de plata en la base sólo  
en la versión Cromo (CR)  
Bombilla: Golpe de viento  
Peso y medidas con embalaje:  
19 kg - 570 x 550 x 2.300 mm



LE VENT D'UN SEUL COUP PLIA LES CIMES.  
EL VIENTO CON UN SOLO GOLPE DOBLÓ LAS CIMAS.

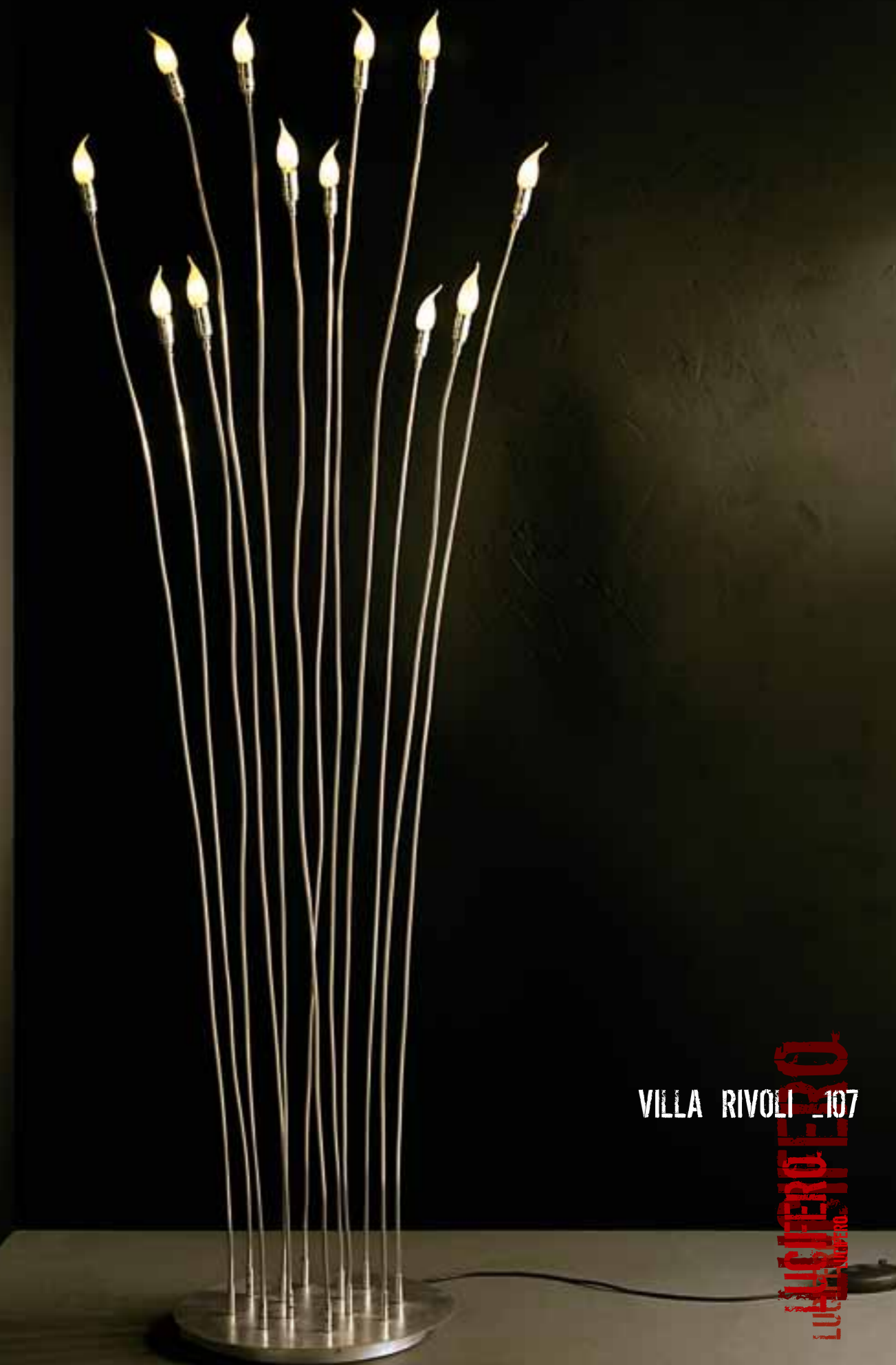

IL VENTO CON UN SOL COLPO PIEGÒ LE CIME.  
THE WIND BENT THE TOPS WITH A SINGLE GUST.

VILLA RIVOLI \_107

D'ALBERTO





Base: Rame  
 Stelo: Rame  
 Finitura: Rame (RA)  
 Opzioni: Cromata (CR), Zincata Bianca (ZB),  
 Gialla (ZG)  
 Particolarità: Steli piegati e legati  
 Trasformatore: Toroidale inserito nella base  
 Lampadina: Alogena Bispina  
 Peso e misure con imballo:  
 17,2 kg - 360 x 300 x 2.150 mm

Base: Copper  
 Stem: Copper  
 Finish: Copper  
 Options: Chrome (CR) White (ZB) Yellow (ZG)  
 galvanized  
 Detail: Tied and bent stems  
 Transformer: Toroidal within the base  
 Lamp: Double plug-in halogen  
 Weight and Measurements including Packaging:  
 17,2 kg - 360 x 300 x 2.150 mm

Socle: Cuivre  
 Tiges: Cuivre  
 Finition: Cuivre (RA)  
 Options: Chromée, Zingagée Blanc (ZB), Jaune (ZG)  
 Particularité: Tiges pliées et liées  
 Transformateur: Toroidal inséré dans le socle  
 Ampoule: Halogène bi-pin  
 Poids et mesures avec emballage:  
 17,2 kg - 360 x 300 x 2.150 mm

Base: Cobre  
 Tubo: Cobre  
 Acabado: Cobre (RA)  
 Opciones: Cromada (CR), Galvanizada con Zinc  
 en Blanco (ZB) y Amarillo (ZG)  
 Particularidades: Tubos doblados y atados  
 Transformador: Toroidal introducido en la base  
 Bombilla: Halógena doble enchufe  
 Peso y medidas con embalaje:  
 17,2 kg - 360 x 300 x 2.150 mm

**Cod. 7009**

OPZIONI: (CR) (ZB) (ZG)

**G R A A**

12 x 20W MAX  
 G4 230/12V

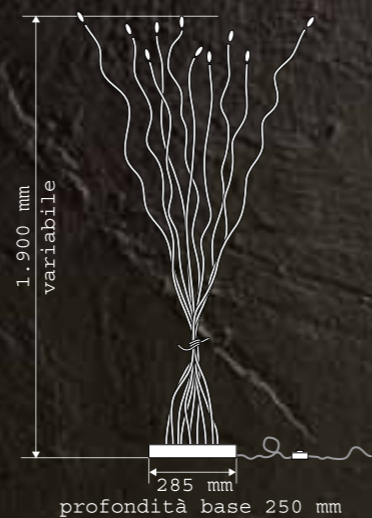

LES ÉTOILES SE SONT POSÉES AU SOMMET.  
 EN LA CIMA SE HAN POSADO LAS ESTRELLAS.

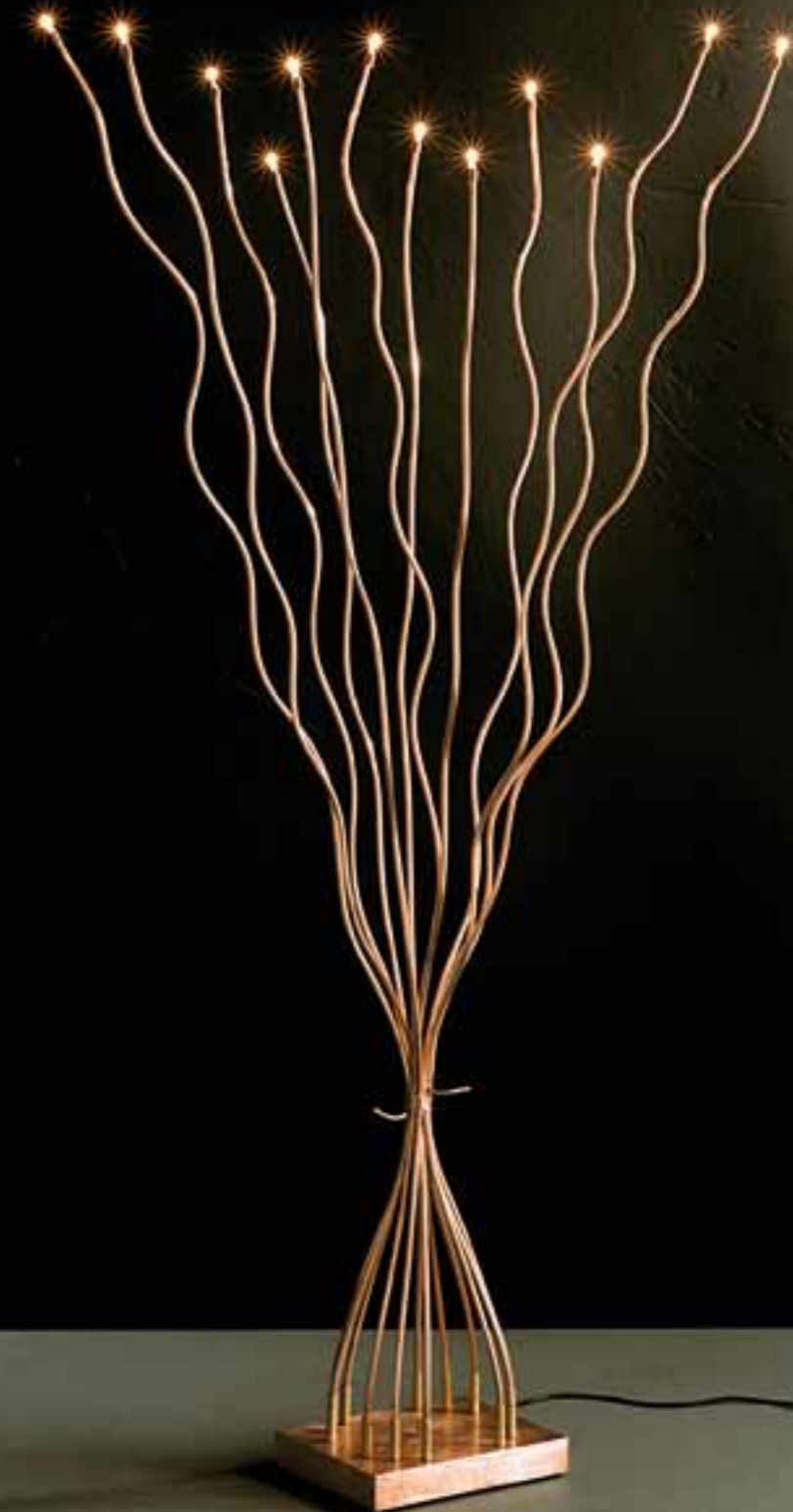

IN CIMA LE STELLE SI SONO POSATE.  
 THE STARS CAME TO REST ON THE UPPERMOST POINTS.

**GRAA** 109  
**DESIGN**





Base: Metallo spazzolato  
 Stelo: Rame  
 Finitura: Zincatura Bianca (ZB)  
 Particolarità: Busto trattato con speciali pellicole iridescenti e finitura siliconica  
 Trasformatore: Toroidale inserito nella base  
 Lampadina: Alogena bispina  
 Peso e misure con imballo:  
 13 Kg - 360 x 470 x 2.150 mm

Base: Brushed metal  
 Stem: Copper  
 Finish: White galvanized (ZB)  
 Detail: Bust coated with unique iridescent films and silicone coating  
 Transformer: Toroidal transformer within the base  
 Lamp: Double plug-in halogen  
 Weight and Measurements including Packaging:  
 13 Kg - 360 x 470 x 2.150 mm

Socle: Métal brossé  
 Tiges: Cuivre  
 Finition: Zingage Blanc (ZB)  
 Particularité: Buste traité avec des films iridescents particuliers et finition siliconée  
 Transformateur: Toroidal inséré dans le socle  
 Ampoule: Halogène bi-pin  
 Poids et mesures avec emballage:  
 13 Kg - 360 x 470 x 2.150 mm

Base: Metal cepillado  
 Tubo: Cobre  
 Acabado: Galvanizado con zinc en Blanco (ZB)  
 Particularidades: Busto tratado con especiales películas iridescentes y acabado con silicona  
 Transformador: Toroidal introducido en la base  
 Bombilla: Halógena doble enchufe  
 Peso y medidas con embalaje:  
 13 Kg - 360 x 470 x 2.150 mm

Cod. 7010

SOTTO IL VESTITO NIENTE

7 x 20W MAX  
 G4 230/12V

CE IP20

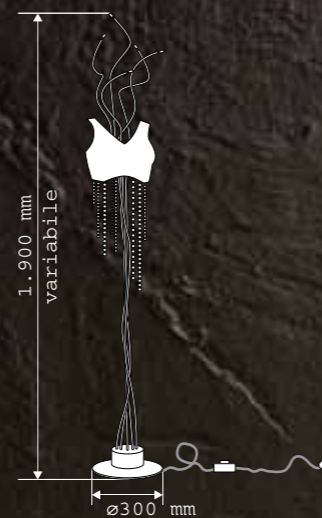

QUE DEMANDER DE PLUS DE LA VIE?  
 ¿QUÉ MÁS QUIERES DE LA VIDA?



SOTTO IL VESTITO NIENTE III

COSA VUOI DI PIÙ DALLA VITA?  
 WHAT MORE DO YOU WANT FROM LIFE?

LUCIFERO





Base: Metallo  
 Stelo: Rame  
 Finitura: Steli zincati bianchi, base verniciata grigia  
 Particolarità: Copertura lampade in vetro silicico - Uccellino su uno stelo  
 Trasformatore: n. 3 Toroidali inseriti nella base  
 Lampadina: Dicroica  
 Peso e misure con imballo:  
 18 kg - 300 x 360 x 2.150 mm

Base: Metal  
 Stem: Copper  
 Finish: Galvanized white stems, grey paint base  
 Detail: Silicone-glass lampshade - little bird on a stem  
 Transformer: no. 3 Toroidal transformers within the base  
 Lamp: Dichroic  
 Weight and Measurements including Packaging:  
 18 kg - 300 x 360 x 2.150 mm

Socle: Métal  
 Tiges: Cuivre  
 Finition: Tiges Zingués Blancs, socle peint gris  
 Particularité: Couverture des lampes en verre siliciné - oiseau sur une tige  
 Transformateurs: 3 toroidaux insérés dans le socle  
 Ampoule: Dichroïque  
 Poids et mesures avec emballage:  
 18 kg - 300 x 360 x 2.150 mm

Base: Metal  
 Tubo: Cobre  
 Acabado: Tubos Galvanizados con Zinc en Blanco, base barnizada gris  
 Particularidades: Cubrelámparas de cristal silicón - Pajarillo en un tubo  
 Transformador: n. 3 Toroidales introducidos en la base  
 Bombilla: Dicroica  
 Peso y medidas con embalaje:  
 18 kg - 300 x 360 x 2.150 mm



Cod. 7011

BAARAS

15 x 20W MAX Ø35  
 G4 230/12V

CE IP20



QUANDO LA NATURE T'ÉMERVEILLE.  
 QUANDO LA NATURALEZA TE ENCANTA.

QUANDO LA NATURA T'INGANTA.  
 WHEN NATURE BEWITCHES YOU.

BAARAS \_113  
 LUCIFERO





Hall Azienda  
Factory Hall



Un creativo Studio Legale  
A creative Law Firm



Centro Estetico  
Beauty Center



CIPPONET - Un forno creativo  
CIPPONET - Creative restaurant



Il "Portico" - San Giorgio Canavese (TO)



Comunicabolo - Studio Fotografico  
Comunicabolo - Photograph Studio



Casa Privata  
Private House



Casa Privata  
Private House





Cod. 7533 CR  
Cod. 7533 RA

C A Y S

1 2x20W MAX  
G4 12V  
220-240/1 2V

CE IP20

Base: Rame  
Ogiva: Rame  
Finitura: Cromo (CR)  
Opzioni: Base e ogiva in rame cod. 7533  
Particolarità: Steli in rame isolato e fogli in alluminio ramato da un lato  
Trasformatori: Elettronici inseriti nell'ogiva  
Lampadina: Alogena bispina  
Peso e misure con imballo:  
5 kg - 750 x 450 x 300 mm

Base: Copper  
Point: Copper  
Finish: Chrome  
Options: Base and point in copper code 7533  
Detail: Insulated copper stems and aluminium leaves on one side  
Transformer: Electronic within the point  
Bulb: Double plug-in halogen  
Weight and Measurements including Packaging:  
5 kg - 750 x 450 x 300 mm

Base: Cuivre  
Ogive: Cuivre  
Finition: Chrome  
Option: Base et ogive en cuivre code 7533  
Particularité: Tiges en cuivre isolé et feuilles en aluminium cuivré d'un côté  
Transformateur: Electronique inséré dans la ogive  
Ampoule: Halogène bi-pin  
Poids et mesures avec emballage:  
5 kg - 750 x 450 x 300 mm

Base: Cobre  
Ojiva: Cobre  
Acabado: Cromo  
Opciones: Base y ojiva de cobre cód. 7533  
Particularidades: Tubos de cobre aislado y folios de aluminio cobrizo por un lado.  
Transformador: Electrónico introducido en la ojiva  
Bombilla: Halógena doble enchufe  
Peso y medidas con embalaje:  
5 kg - 750 x 450 x 300 mm

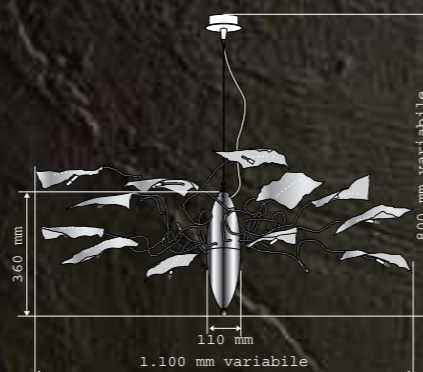

LIEURS LÉGÈRES POUR ACCUEILLIR LA NUIT.  
LIEVES RESPLANDORES PARA ACOGER A LA NOCHE.

LIEVI BAGLIORI AD ACCOGLIERE LA NOTTE.  
BRIEF FLASHES OF LIGHT THAT GREET THE NIGHT.

CAYS \_117  
LUCIFERO  
LUCIFERO





Cod. 7535 VG  
Cod. 7535 VN

SOKAY

4x75W MAX  
G53 | 2V  
220-240/1 2V

CE IP20



Base: Metallo  
Finitura: Verniciatura grigia (VG)  
Opzioni: Verniciatura nera cod. 7535 VN  
Steli: Rame cromato  
Lampadina: Halospot  
Trasformatori: Toroidali inseriti nella base  
Peso e misure con imballo:  
7,5 kg - 750 x 450 x 300 mm

Base: Metal  
Finish: Grey paint  
Options: Black paint code 7535VN  
Stems: Chrome plated Copper  
Transformers: Toroidals within the base  
Bulb: Halospot  
Weight and Measurements including Packaging:  
7,5 kg - 750 x 450 x 300 mm

Base: Métal  
Finition: Peinture grise (VG)  
Option: Peinture noire code 7535 VN  
Tiges: Cuivre chromé  
Transformateurs: Toroïdaux inséré dans la base  
Ampoule: Halospot  
Poids et mesures avec emballage:  
7,5 kg - 750 x 450 x 300 mm

Base: Metal  
Acabado: Barnizada gris (VG)  
Opciones: Barnizada Negra cód. 7535 VN  
Tubos: Cobre cromado  
Transformadores: Toroidales introducido en la base  
Bombilla: Halospot  
Peso y medidas con embalaje:  
7,5 kg - 750 x 450 x 300 mm

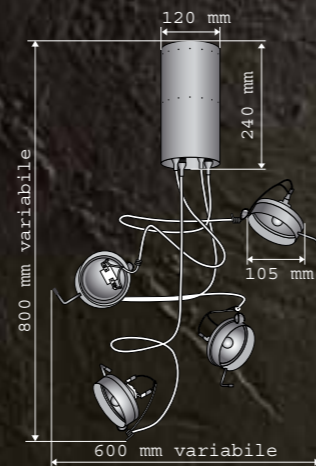

CROISEMENTS DE LUMIÈRE POUR JOUER AVEC L'ÉTHÉR.  
CRUCES DE LUZ JUEGAN CON EL ÉTER.

INCROCI DI LUCE A GIOCARE CON L'ETERE.  
CRISSCROSSES OF LIGHT PLAYING WITH HEAVENS.

SOKAY \_119  
LUCIFERO  
LUCIFERO





Cod. 7522 white

Cod. 7523 black

RAKKUS

3 x 75W MAX  
E27 230V



CE IP20



Base: Metallo  
Finitura: Cromo  
Braccio: Resina verniciata  
Particolarità: Paralume in resina nera o naturale  
Lampadina: Goccia E27  
Peso e misure con imballo:  
10,5 kg - 800 x 530 x 800 mm

Base: Metal  
Stem: Painted resin  
Finish: Chrome  
Detail: Lamp shade available in black or natural shade resin  
Bulb: E27 light bulb  
Weight and Measurements including Packaging:  
10,5 kg - 800 x 530 x 800 mm

Base: Métal  
Finition: Chrome  
Bras: Résine peinte  
Particularité: Abat-jour en résine noire ou naturelle  
Ampoule: Goutte E27  
Poids et mesures avec emballage:  
10,5 kg - 800 x 530 x 800 mm

Base: Metal  
Acabado: Cromo  
Brazo: Resina barnizada  
Particularidades: Pantalla de resina negra o natural  
Bombilla: Gota E27  
Peso y medidas con embalaje:  
10,5 kg - 800 x 530 x 800 mm

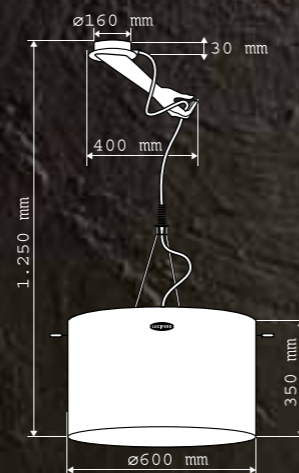

BLANC ET NOIR, ÉTERNELLE DUALITÉ.  
BLANCO Y NEGRO, ETERNA DUALIDAD.

BIANCO E NERO, ETERNA DUALITÀ.  
BLACK AND WHITE, THE NEVER-ENDING DUALISM.

RAKKUS \_121  
LUCCHERO LORO





Base: Rame  
 Stelo: Cromato  
 Finitura: Cromo  
 Particolarità: Tessuto Metallico e pendagli  
 Lampadina: Alogena  
 Peso e misure con imballo:  
 3,5 kg - 460 x 120 x 1.130 mm

Base: Copper  
 Stem: Chrome  
 Finish: Chrome  
 Detail: Metallic net fabric and crystal pendants  
 Lamp: Halogen  
 Weight and Measurements including Packaging:  
 3,5 kg - 460 x 120 x 1.130 mm

Base: Cuivre  
 Tiges: Cromé  
 Finition: Chrome  
 Particularité: Tissu métallique et pendants  
 Ampoule: Halogène  
 Poids et mesures avec emballage:  
 3,5 kg - 460 x 120 x 1.130 mm

Base: Cobre  
 Tubo: Cromo  
 Acabado: Cromo  
 Particularidades: Tejido Metálico y colgantes  
 Bombilla: Halógena  
 Peso y medidas con embalaje:  
 3,5 kg - 450 x 120 x 1.130 mm

Cod. 7524

BATHIM

2 x 60W MAX  
 G9 230V

CE IP20    

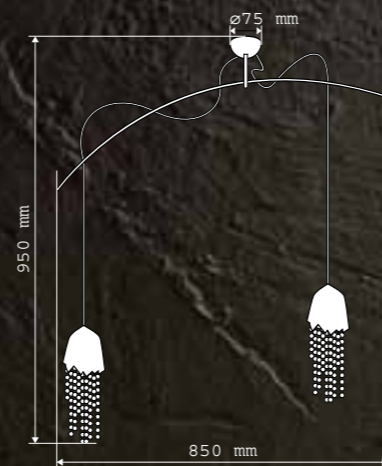

HARMONIE ORIENTALE ÉQUILIBRÉE.  
 EQUILIBRADA ARMONÍA ORIENTAL.

EQUILIBRATA ARMONIA ORIENTALE.  
 BALANCED ORIENTAL HARMONY.

BATHIM \_123

LUCIFERO  
 LUCIFERO





**Cod. 7529 CR**

OPZIONI: (RA) (ZB) (ZG)

**BEBAL 15**

15 x 20W MAX  
G4 230/12V

CE IP20   

Base: Rame  
Finitura: Cromo (CR)  
Opzioni: Rame (RA), Zincatura Bianca (ZB)  
Gialla (ZG)  
Particolarità: Steli modellabili  
Trasformatore: Toroidale inserito nella base  
Lampadina: Alogena bispina  
Peso e misure con imballo:  
15 kg - 800 x 800 x 930 mm

Base: Copper  
Finish: Chrome (CR)  
Options: Copper (RA), White (ZB) Yellow (ZG)  
galvanized  
Detail: Mouldable stems  
Transformer: Toroidal within the base  
Lamp: Double plug-in halogen  
Weight and Measurements including Packaging:  
15 kg - 800 x 800 x 930 mm

Base: Cuivre  
Finition: Chrome (CR)  
Options: Cuivre (RA), Zingage Blanc (ZB),  
Jaune (ZG)  
Particularité: Tiges modelables  
Transformateur: Toroidal inséré dans le socle  
Ampoule: Halogène bi-pin  
Poids et mesures avec emballage:  
15 kg - 800 x 800 x 930 mm

Base: Cobre  
Acabado: Cromo (CR)  
Opciones: Cobre (RA), Galvanizado con zinc en  
Blanco (ZB), Amarillo (ZG)  
Particularidades: Tubos moldeables  
Transformador: Toroidal introducido en la base  
Bombilla: Halógena doble enchufe  
Peso y medidas con embalaje:  
15 kg - 800 x 800 x 930 mm

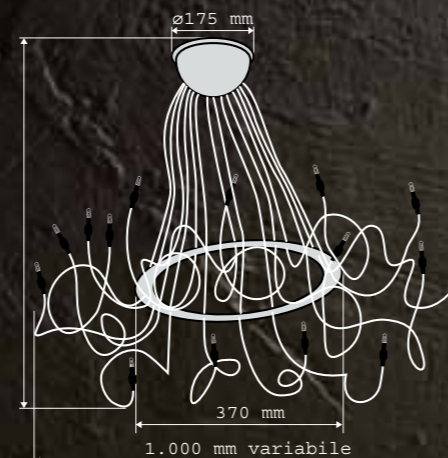

**BEBAL 15 \_125**

**OSIMILIA**

VIRTUOSITÉS HARMONIEUSES D'ORIGINALITÉ.  
ARMÓNICOS VIRTUOSISMOS DE ORIGINALIDAD.

ARMONICI VIRTUOSISMI DI ORIGINALITÀ.  
HARMONIOUS VIRTUOSITIES OF ORIGINALITY.



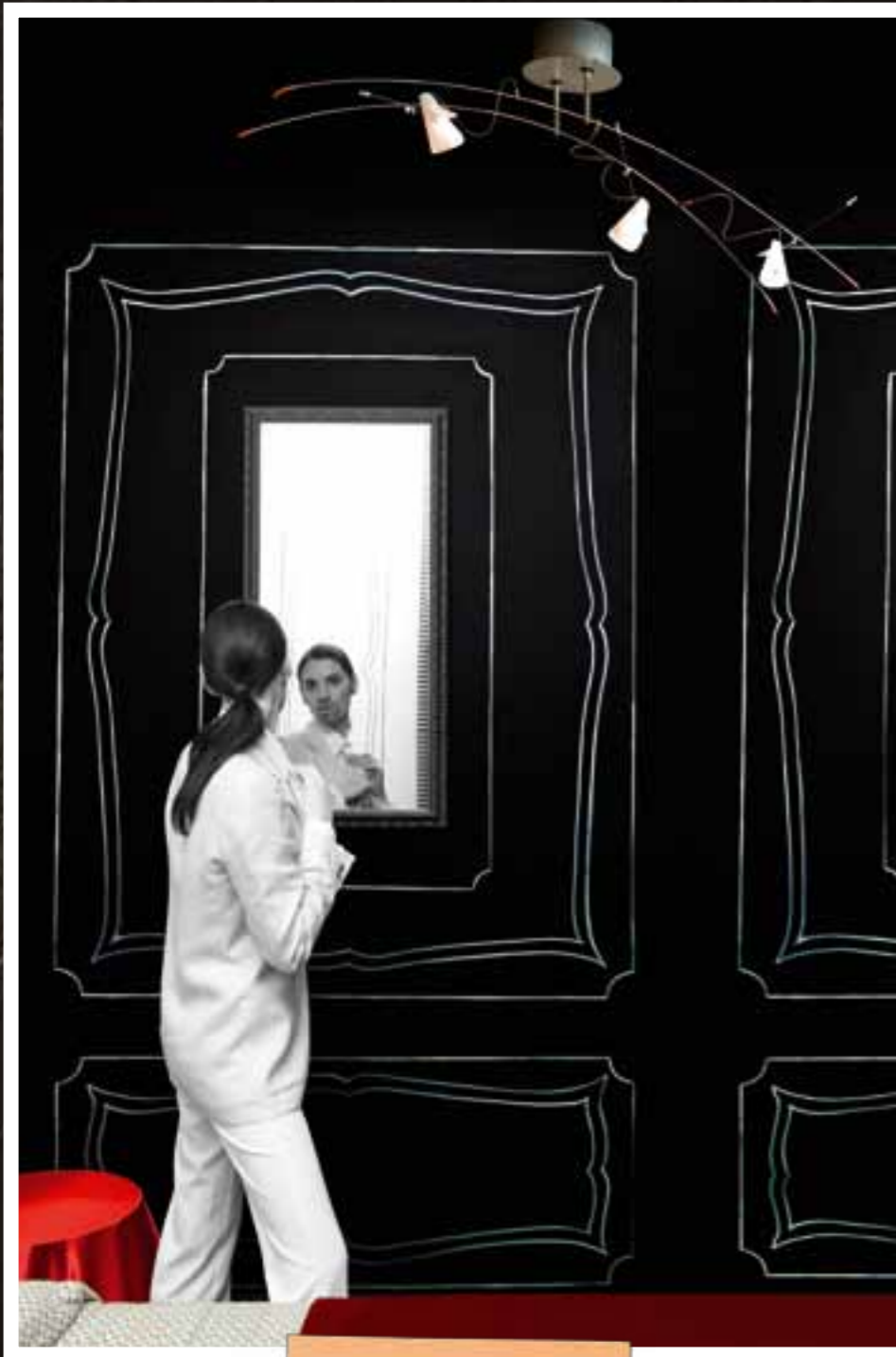

Base: Metallo  
 Steli: Cromati  
 Finitura: Base verniciata grigia, stelo cromato  
 Particolarità: Coprilampada in vetro siliconico  
 Trasformatore: Toroidale inserito nella base  
 Lampadina: Dicroica  
 Peso e misure con imballo:  
 8 kg - 360 x 2.150 x 300 mm

Base: Metal  
 Stems: Chrome  
 Finish: Gray painted (base), chrome stem  
 Detail: Silicone-glass lampshade  
 Transformer: Toroidal within the base  
 Lamp: Dichroic  
 Weight and Measurements including Packaging:  
 8 kg - 360 x 2.150 x 300 mm

Base: Métal  
 Tiges: Cromées  
 Finition: Base peinte gris, tiges chromée  
 Particularité: Abat-jour en verre siliconé  
 Transformateur: Toroidal inséré dans la base  
 Ampoule: Dichroïque  
 Poids et mesures avec emballage:  
 8 kg - 360 x 2.150 x 300 mm

Base: Metal  
 Tubo: Cromo  
 Acabado: Base barnizada gris, tubo cromado  
 Particularidades: Cubrelámpara de cristal silicona  
 Transformador: Toroidal introducido en la base  
 Bombilla: Dicroica  
 Peso y medidas con embalaje:  
 8 kg - 360 x 2.150 x 300 mm



**Cod. 7504**

**NEKIR**

3 x 50W MAX Ø5 I  
 GU5,3 230/12V



**Cod. 7504 BIS**

**NEKIR**

4 x 50W MAX Ø5 I  
 GU5,3 230/12V

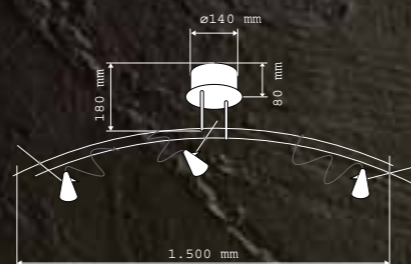
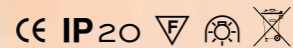

**NEKIR \_127**

LA SOLUTION DE CERTAINS PROBLÈMES VIEN DU HAUT.  
 LA SOLUCIÓN DE CIERTOS PROBLEMAS VIENE DESDE ARRIBA.

LA SOLUZIONE DI CERTI PROBLEMI VIENE DALL'ALTO.  
 THE SOLUTION TO CERTAIN PROBLEMS COMES FROM ON HIGH.

**LUCCIFERO**





**Cod. 7507 VB**

OPZIONI: (CR) (RA) (ZB) (ZG) (VN)

**CINCIALLEGRE**

9 x 40W (60W MAX)  
E14 230V

CE IP20



Base: Metallo  
Stelo: Rame  
Finitura: Base e steli verniciati bianchi (VB)  
Opzioni: Cromo (CR) , Rame (RA), Zincatura  
Bianca (ZB) Gialla (ZG), Verniciatura Nera (VN)  
Particolarità: Steli modellabili  
Lampadina: Colpo di vento  
Peso e misure con imballo:  
7,5 kg - 560 x 460 x 750 mm

Opzioni: Con più steli

Base: Metal  
Stem: Copper  
Finish: White painted base and stems  
Options: Chrome (CR) Copper (RA), Galvanized  
White (ZB), Yellow (ZG), Black Paint (VN)  
Detail: Mouldable stems  
Lamp: Gust of wind  
Weight and Measurements including Packaging:  
7.5 kg - 560 x 460 x 750 mm

Options: More stems

Base: Métal  
Tiges: Cuivre  
Finition: Base et tiges Peintes Blanc (VB)  
Options: Chrome (CR), Cuivre (RA), Zingage  
Blanc (ZB), Jaune (ZG), Peinture Noire (VN)  
Particularité: Tiges modelables  
Ampoule: Coup de vent  
Poids et mesures avec emballage:  
7,5 kg - 560 x 460 x 750 mm

Options: Avec plusieurs tiges

Base: Metal  
Tubo: Cobre  
Acabado: Base y tubos Barnizados Blancos (VB)  
Opciones: Cromo (CR), Cobre (RA), Galvanizado  
con Zinc en Blanco (ZB) Amarillo (ZG), Barniza-  
do Negro (VN)  
Particularidades: Tubos moldeables  
Bombilla: Golpe de viento  
Peso y medidas con embalaje:  
7.5 kg - 560 x 460 x 750 mm

Opciones: Con más tubos

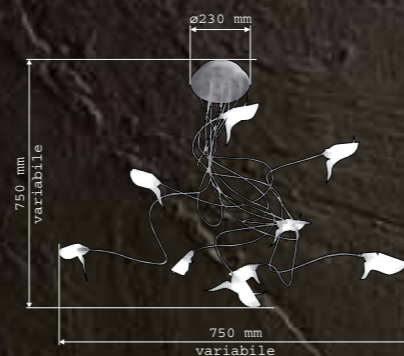

CINCIALLEGRE \_129

UN ENVOL DE LUMIÈRES.  
UN VUELO DE LUCES.

UN VOLO DI LUCI.  
A FLIGHT OF LIGHT.

DISEGNO  
LUMINOTECNICO  
LUMINOTECNICO







Cod. 7510

Z O T

150W MAX  
R7s 230V

CE IP20  

Base: Alluminio verniciato grigio  
Stelo: Cromato  
Particolarità: Cavi trasparenti e collare cromato, gira su se stessa  
Lampadina: Alogena lineare corta  
Peso e misure con imballo:  
1,7 kg - ø155 x 1.110 mm

Base: Grey paint aluminium  
Stem: Chrome  
Detail: Transparent cables and chromium plated collar, it turns on itself  
Lamp: Linear short halogen  
Weight and Measurements including Packaging:  
1,7 kg - ø155 x 1.110 mm

Base: Aluminium peint gris  
Tige: Chrome  
Particularité: Câbles transparents et collier chromé, tourne sur elle-même  
Ampoule: Halogène linéaire courte  
Poids et mesures avec emballage:  
1,7 kg - ø 155 x 1.110 mm

Base: Aluminio barnizado gris  
Tubo: Cromo  
Particularidades: Cables transparentes y corona cromada, gira sobre sí misma  
Bombilla: Halógena lineal corta  
Peso y medidas con embalaje:  
1,7 kg - ø155 x 1.110 mm

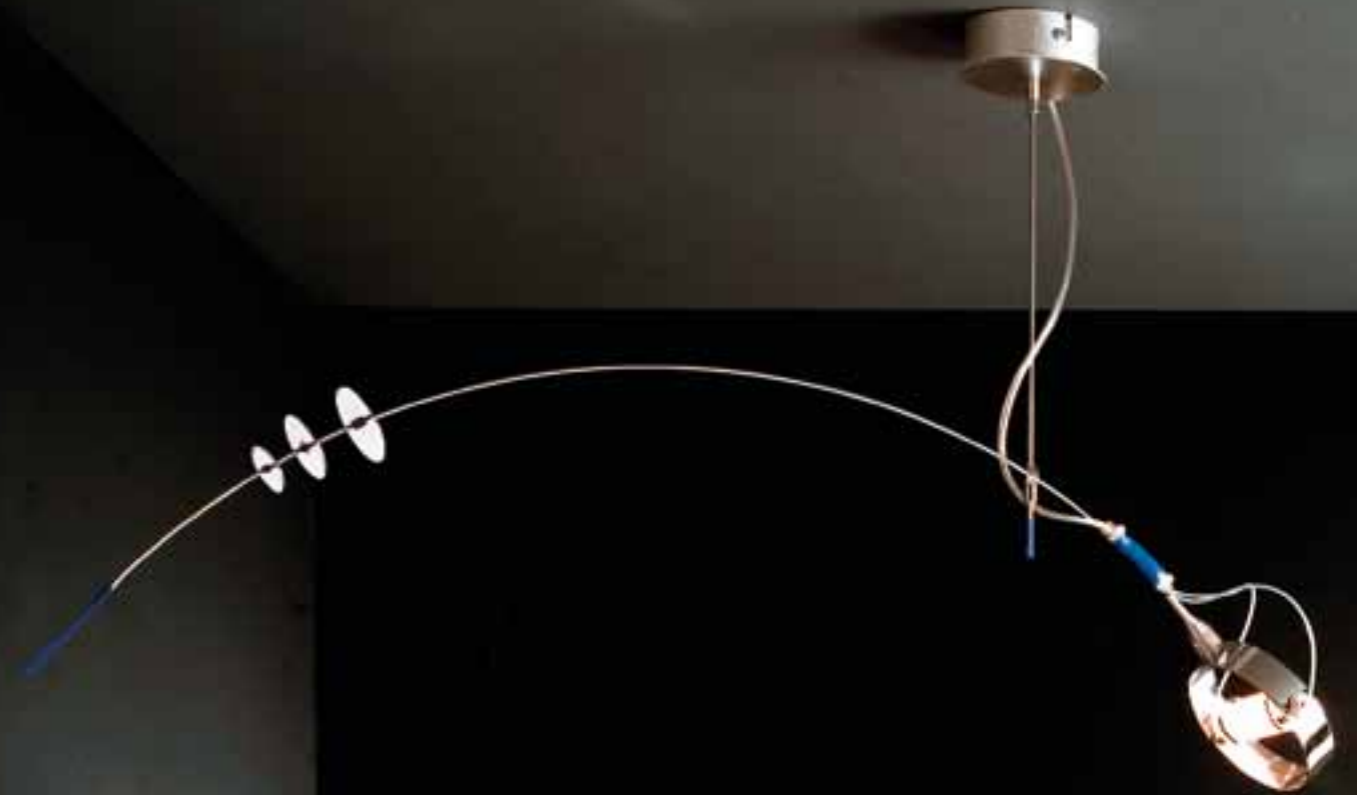

ZOT \_131  
LUCIFERO

LÉGÈRE COMME UN MOBILE, SA LUMIÈRE FEND L'OBSCURITÉ.  
MUY LIGERA/INCRÉIBLEMENTE LIGERA (COMO UN MÓVIL), SU LUZ CORTA LA OSCURIDAD.

LEGGERA COME UN MOBIL, LA SUA LUCE FENDE IL BUIO.  
LIGHT AS A MOBILE, ITS LIGHT SPLITS THE DARK.





Base: Alluminio verniciato grigio  
 Stelo: Cromato  
 Particolarità: Cavi trasparenti e collare cromato, girano su se stessi  
 Lampadina: Alogena lineare corta  
 Peso e misure con imballo:  
 2,7 kg - 1.130 x 460 x 120 mm

Base: Grey paint aluminium  
 Stems: Chrome  
 Detail: Transparent cables and chromium plated collar, they each spin independently  
 Lamp: Linear short halogen  
 Weight and Measurements including Packaging:  
 2,7 kg - 1.130 x 460 x 120 mm

Base: Aluminium peint gris  
 Tiges: Chrome  
 Particularité: Câbles transparents et collier chromé, tournent sur elles-mêmes  
 Ampoule: Halogène linéaire courte  
 Poids et mesures avec emballage:  
 2,7 kg - 1.130 x 460 x 120 mm

Base: Aluminio barnizado gris  
 Tubo: Cromo  
 Particularidades: Cables transparentes y corona cromada, giran sobre sí mismas  
 Bombilla: Halógena lineal corta  
 Peso y medidas con embalaje:  
 2,7 kg - 1.130 x 460 x 120 mm

Cod. 7511

ZOT 2

2 x 150W MAX  
 R7s 230V

CE IP20

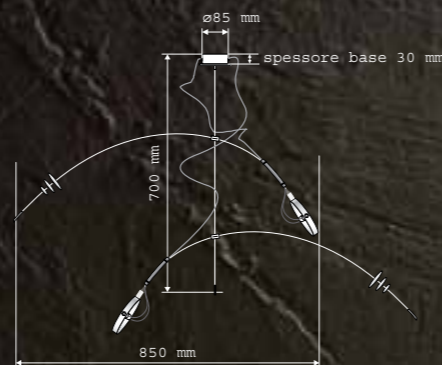

ZOT 2\_133

LUCIFERO

QUANDO UNE NE SUFFIT PAS.  
 CUANDO UNA NO ES BASTANTE.

QUANDO UNA NON BASTA.  
 WHEN ONE ISN'T ENOUGH.





Base: Rame  
 Stelo: Rame  
 Finitura: Zincatura gialla (ZG)  
 Opzioni: Cromo (CR) Rame (RA) zincatura  
 Bianca (ZB)  
 Particolarità: Steli modellabili  
 Trasformatore: Toroidale inserito nella base  
 Lampadina: Alogena bispina  
 Peso e misure con imballo:  
 3,9 kg - 250 x 400 x 500 mm

Base: Copper  
 Stem: Copper  
 Finish: Yellow galvanized  
 Options: Chrome (CR), Copper (RA), White (ZB)  
 galvanized  
 Detail: Mouldable stems  
 Transformer: Toroidal within the base  
 Lamp: Double plug-in halogen  
 Weight and Measurements including Packaging:  
 3,9 kg - 250 x 400 x 500 mm

Base: Cuivre  
 Tige: Cuivre  
 Finition: Zingage Jaune (ZG)  
 Options: Chrome (CR), Cuivre (RA), Zingage  
 Blanc (ZB)  
 Particularité: Tiges modelables  
 Transformateur: Toroidal inséré dans la base  
 Ampoule: Halogène bi-pin  
 Poids et mesures avec emballage:  
 3,9 kg - 250 x 400 x 500 mm

Base: Cobre  
 Tubo: Cobre  
 Acabado: Galvanizado con Zinc en Amarillo (ZG)  
 Opciones: Cromo (CR) Cobre (RA) Galvanizado  
 con Zinc en Blanco (ZB)  
 Particularidades: Tubos moldeables  
 Transformador: Toroidal introducido en la base  
 Bombilla: Halógena doble enchufe  
 Peso y medidas con embalaje:  
 3,9 kg - 250 x 400 x 500 mm



**Cod. 7515 ZG**

OPZIONI: (CR) (RA) (ZB)

**O R I A S**

5 x 20W MAX  
 G4 230/12V

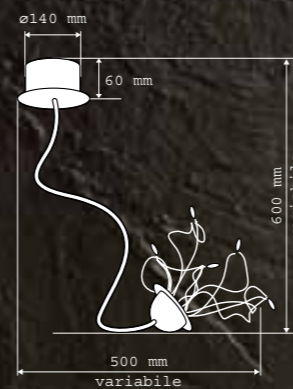

LES LUCIOLES S'AMUSENT.  
 LAS LUCIÉRNAGAS SE DIVIERTEN.

LE LUCCIOLE SI DIVERTONO.  
 FIREFLIES ENJOY THEMSELVES.

**O R I A S** \_135  
**LUCCIFERO**  
 LUCIFERO





**Cod. 7532 ZG**

OPZIONI: (CR) (ZB) (VB) (VN)

MINI FAAL

5 x 20W MAX  
G4 230/12V

CE IP20



Base: Metallo spazzolato  
Stelo: Rame  
Finitura: Zincatura gialla e foglia rame  
Opzioni: Cromo (CR), Zincatura Bianca (ZB), Verniciatura Bianca (VB) Nera (VN)  
Particolarità: Steli modellabili  
Trasformatore: Toroidale inserito nella base  
Lampadina: Alogena bispina  
Peso e misure con imballo:  
5,5 kg - 750 x 450 x 300 mm

Base: Brushed metal  
Stem: Copper  
Finish: Galvanized Yellow and copper leaves  
Options: Chrome (CR), Galvanized White (ZB), White Paint (VB), Black (VN)  
Detail: Mouldable stems  
Transformer: Toroidal within the base  
Lamp: Double plug-in halogen  
Weight and Measurements including Packaging:  
5,5 kg - 750 x 450 x 300 mm

Base: Métal brossé  
Tiges: Cuivre  
Finition: Zingage Jaune et feuille cuivre  
Options: Chrome (CR), Zingage Blanc (ZB), Peinture Blanche (VB), Noire (VN)  
Particularité: Tiges modelables  
Transformateur: Toroidal inséré dans la base  
Ampoule: Halogène bi-pin  
Poids et mesures avec emballage:  
5,5 kg - 750 x 450 x 300 mm

Base: Metal cepillado  
Tubo: Cobre  
Acabado: Galvanizado con Zinc en Amarillo y hoja de cobre  
Opciones: Cromo (CR), Galvanizado con zinc en Blanco (ZB), Barnizado Blanco (VB) Negro (VN)  
Particularidades: Tubos moldeables  
Transformador: Toroidal introducido en la base  
Bombilla: Halógena doble enchufe  
Peso y medidas con embalaje:  
5,5 kg - 750 x 450 x 300 mm

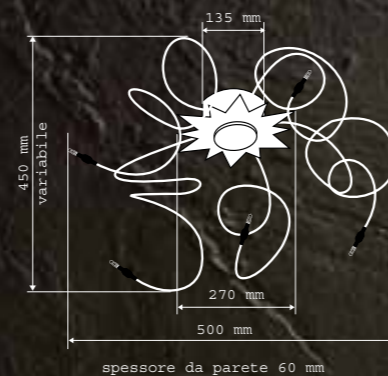
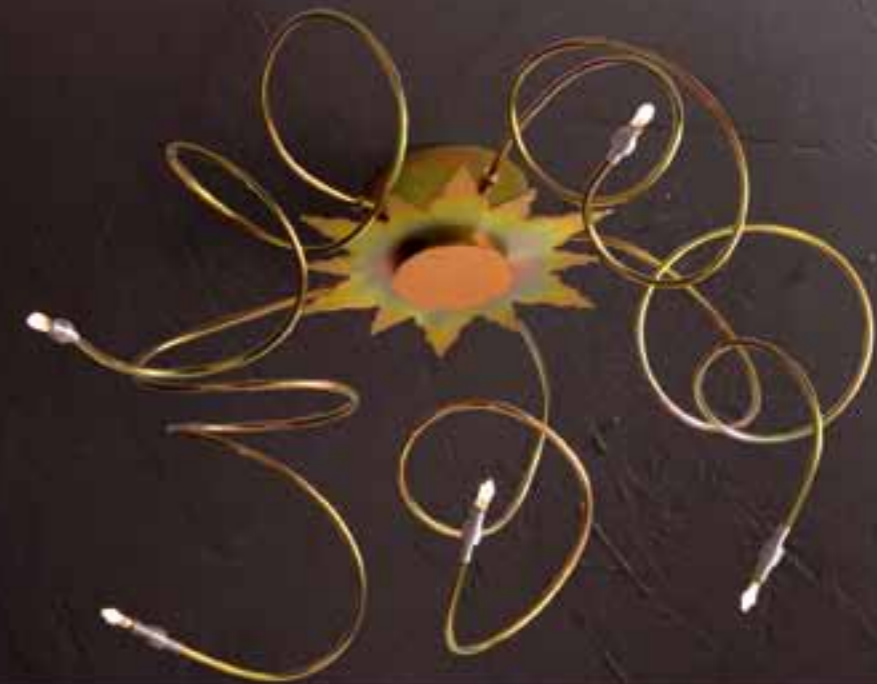

BOUCLES RAYONNANTES, LES ESPRITS SURSAUTENT.  
RIZOS RESPLANDECIENTES, ESTREMECEN EL ESPÍRITU.

RICCIOLI SFAVILLANTI, GLI ANIMI SUSSULTANO.  
SPARKLING CURLS, SOULS LEAP.

MINI FAAL 137  
LUCIFERO





Base: Metallo  
 Stelo: Rame  
 Finitura: Cromo (CR)  
 Opzioni: Zincatura Bianca (ZB), Gialla (ZG),  
 Verniciatura Bianca (VB) Nera (VN)  
 Particolarità: Steli modellabili  
 Trasformatore: Toroidale inserito nella base  
 Lampadina: Alogena bispina  
 Peso e misure con imballo:  
 11 kg - 750 x 560 x 460 mm

Opzioni: Con meno steli

Base: Metal  
 Stem: Copper  
 Finish: Chrome  
 Options: Galvanized White (ZB) Yellow (ZG),  
 White Paint (VB), Black (VN)  
 Detail: Mouldable stems  
 Transformer: Toroidal within the base  
 Lamp: Double plug-in halogen  
 Weight and Measurements including Packaging:  
 11 kg - 750 x 560 x 460 mm

Options: With fewer stems

Base: Métal  
 Tiges: Cuivre  
 Finition: Chrome  
 Options: Zingage Blanc (ZB), Jaune (ZG),  
 Peinture Blanche (VB), Noire (VN)  
 Particularité: Tiges modelables  
 Transformateur: Toroïdal inséré dans la base  
 Ampoule: Halogène bi-pin  
 Poids et mesures avec emballage:  
 11 kg - 750 x 560 x 460 mm

Options: Avec moins de tiges

Base: Metal  
 Tubo: Cobre  
 Acabado: Cromo (CR)  
 Opciones: Galvanizado con zinc en Blanco (ZB),  
 Amarillo (zg), Barnizado Blanco (VB) Negro (VN)  
 Particularidades: Tubos moldeables  
 Transformador: Toroidal introducido en la base  
 Bombilla: Halógena doble enchufe  
 Peso y medidas con embalaje:  
 11 kg - 750 x 560 x 460 mm

Opciones: Con menos tubos

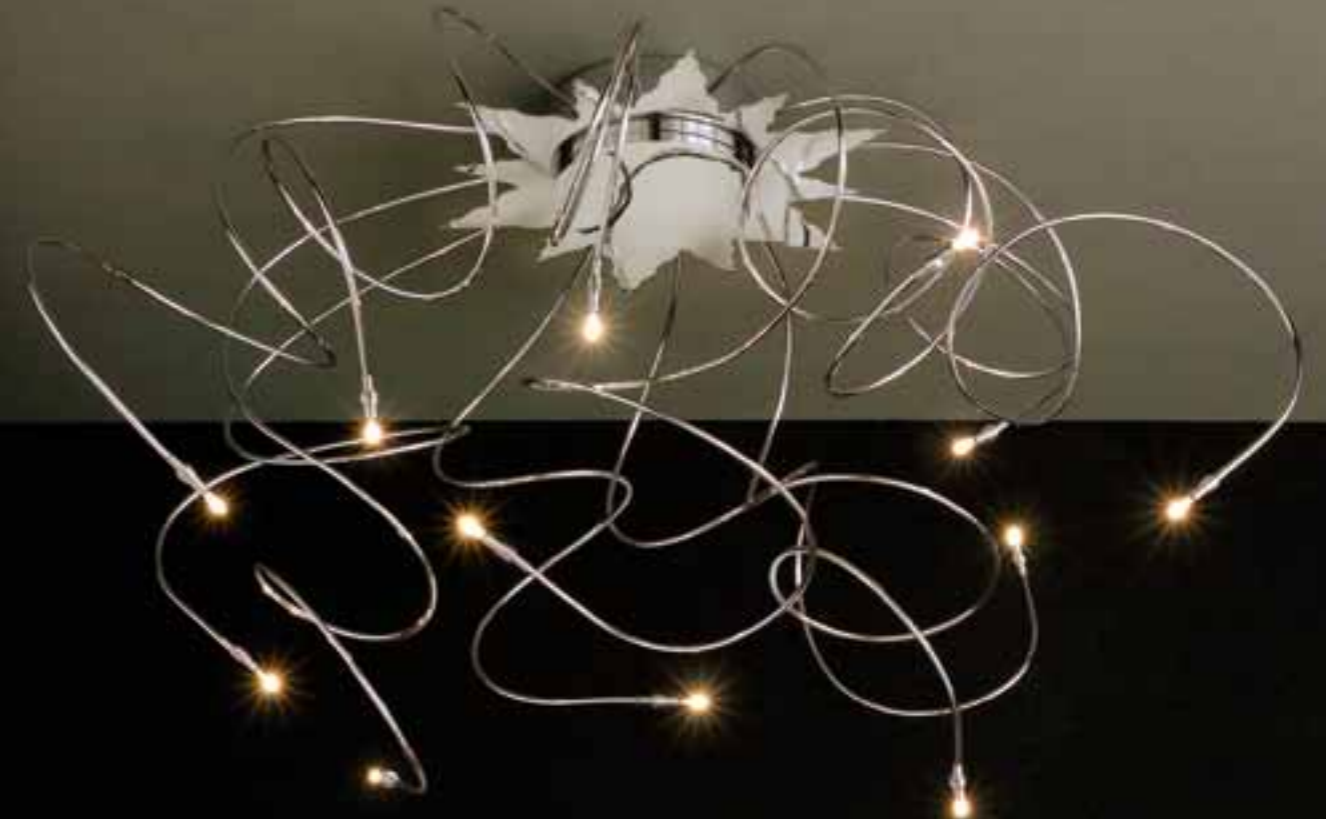

**Cod. 7518/12 CR**

OPZIONI: (ZB) (ZG) (VB) (VN)

FAAL SMALL

12 x 20W MAX  
 G4 230/12V

CE IP20

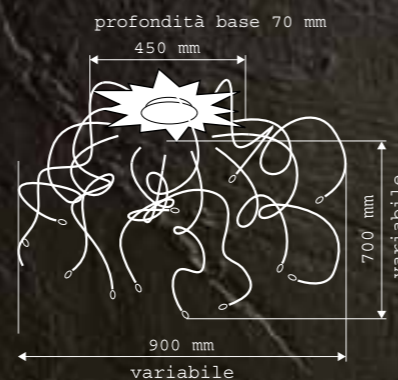

FAAL SMALL 139

LA NUIT DES ÉTOILES FILANTES: FAITES UN VŒU!  
 LA NOCHE DE LAS ESTRELLAS FUGACES: PIDE UN DESEO.

LA NOTTE DELLE STELLE CADENTI, ESPRIMI UN DESIDERIO.  
 THE NIGHT OF FALLING STARS, MAKE A WHISH

D'ALBERTO





**Cod. 7516 ZG**

OPZIONE: (ZB)

F A A L

12 x 20W MAX  
G4 230/12V



Base: Metallo spazzolato  
Stelo: Rame  
Finitura: Zincatura gialla e foglia rame  
Opzione: Zincatura Bianca (ZB)  
Particolarità: Steli modellabili  
Trasformatore: Toroidale inserito nella base  
Lampadina: Alogena bispina  
Peso e misure con imballo:  
15 kg - 800 x 800 x 520 mm

Opzione: Con più steli

Base: Brushed metal  
Stem: Copper  
Finish: Yellow galvanized and copper-foil  
Option: White galvanized (ZB)  
Detail: Mouldable stems  
Transformer: Toroidal within the base  
Lamp: Double plug-in halogen  
Weight and Measurements including Packaging:  
15 kg - 800 x 800 x 520 mm

Option: More stems

Base: Métal brossé  
Tiges: Cuivre  
Finition: Zingage Jaune et feuille cuivre  
Options: Zingage Blanc (ZB)  
Particularité: Tiges modelables  
Transformateur: Toroidal inséré dans la base  
Ampoule: Halogène bi-pin  
Poids et mesures avec emballage:  
15 kg - 800 x 800 x 520 mm

Option: Avec plusieurs tiges

Base: Metal cepillado  
Tubo: Cobre  
Acabado: Galvanizado con zinc en Amarillo y hoja de cobre  
Opciones: Galvanizado con zinc en Blanco (ZB)  
Particularidades: Tubos moldeables  
Transformador: Toroidal introducido en la base  
Bombilla: Halógena doble enchufe  
Peso y medidas con embalaje:  
15 kg - 800 x 800 x 520 mm

Opciones: Con más tubos

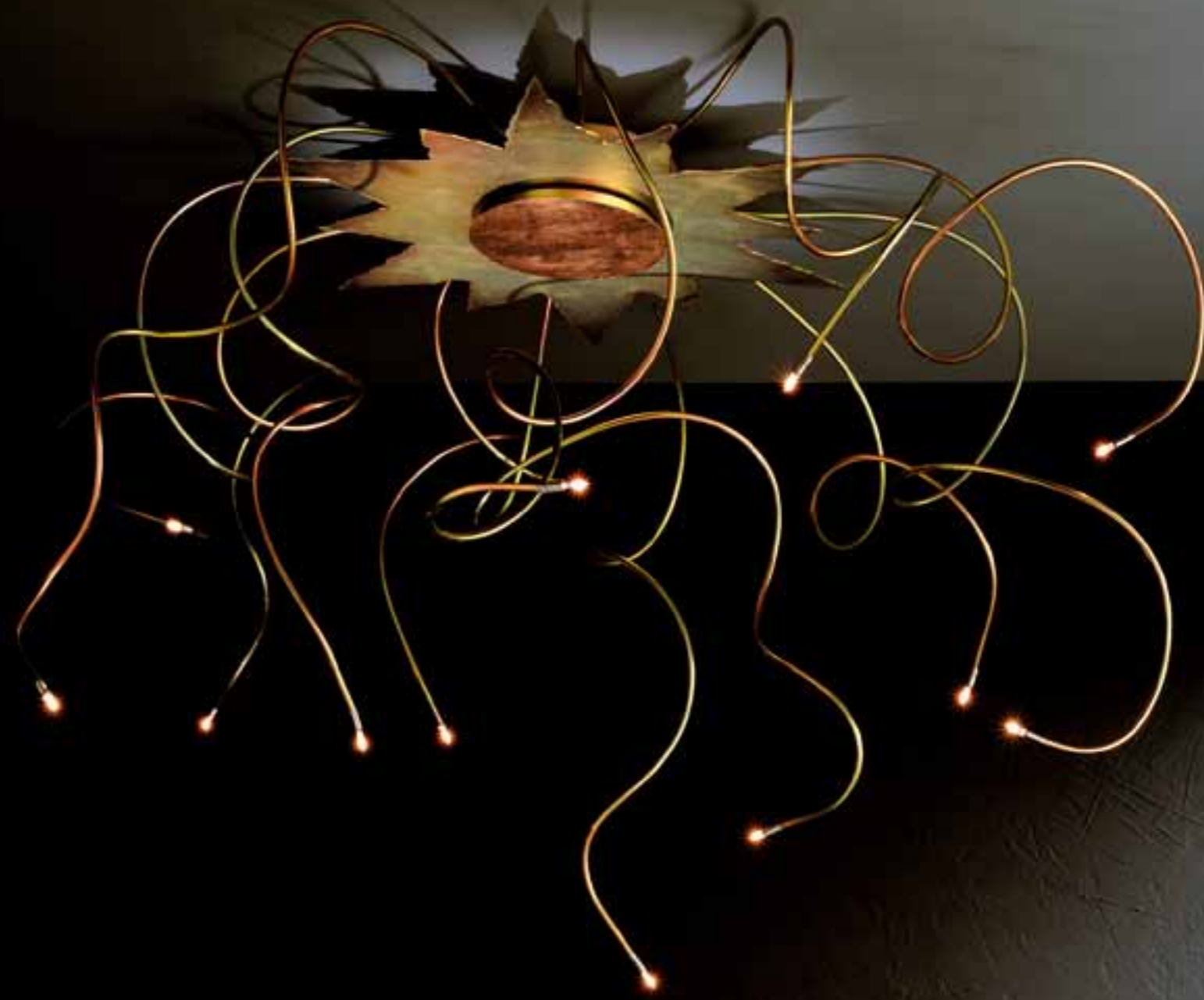
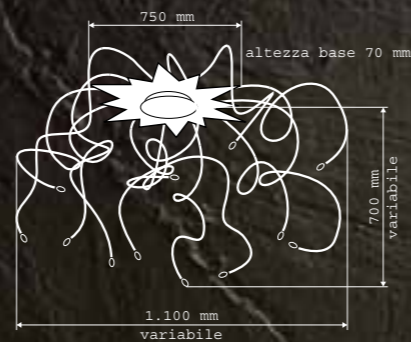

**OSCAR DE LA FUENTE**  
**FAAL\_141**

LE SOLEIL ILLUMINE LES ESPRITS.  
EL SOL ILUMINA EL ESPIRITU.

IL SOLE ILLUMINA GLI ANIMI.  
THE SUN LIGHTS UP THE SOUL.





Base: Metallo  
 Stelo: Plexiglass sabbiato  
 Finitura: Cromo  
 Particolarità: Veri fiori finti  
 Trasformatore: Toroidale inserito nella struttura  
 Lampadina: Alogena bispina + risparmio energetico  
 Peso e misure con imballo:  
 5,6 kg - 750 x 450 x 300 mm

Base: Metal  
 Stem: Sandblasted plexiglas  
 Finish: Chrome  
 Detail: Genuine artificial flowers  
 Transformer: Toroidal within the structure  
 Lamp: Double plug-in halogen + energy-saving  
 Weight and Measurements including Packaging:  
 5,6 kg - 750 x 450 x 300 mm

Base: Métal  
 Tiges: Plexiglas sablé  
 Finition: Chrome  
 Particularité: Vraies fausses fleurs  
 Transformateur: Toroidal inséré dans la structure  
 Ampoule: Halogène bi-pin + économie d'énergie  
 Poids et mesures avec emballage:  
 5,6 kg - 750 x 450 x 300 mm

Base: Metal  
 Tubo: Plexiglas arenado  
 Acabado: Cromo  
 Particularidades: Verdaderas flores falsas  
 Transformador: Toroidal introducido en la estructura  
 Bombilla: Halógena doble enchufe + bajo consumo energético  
 Peso y medidas con embalaje:  
 5,6 kg - 750 x 450 x 300 mm

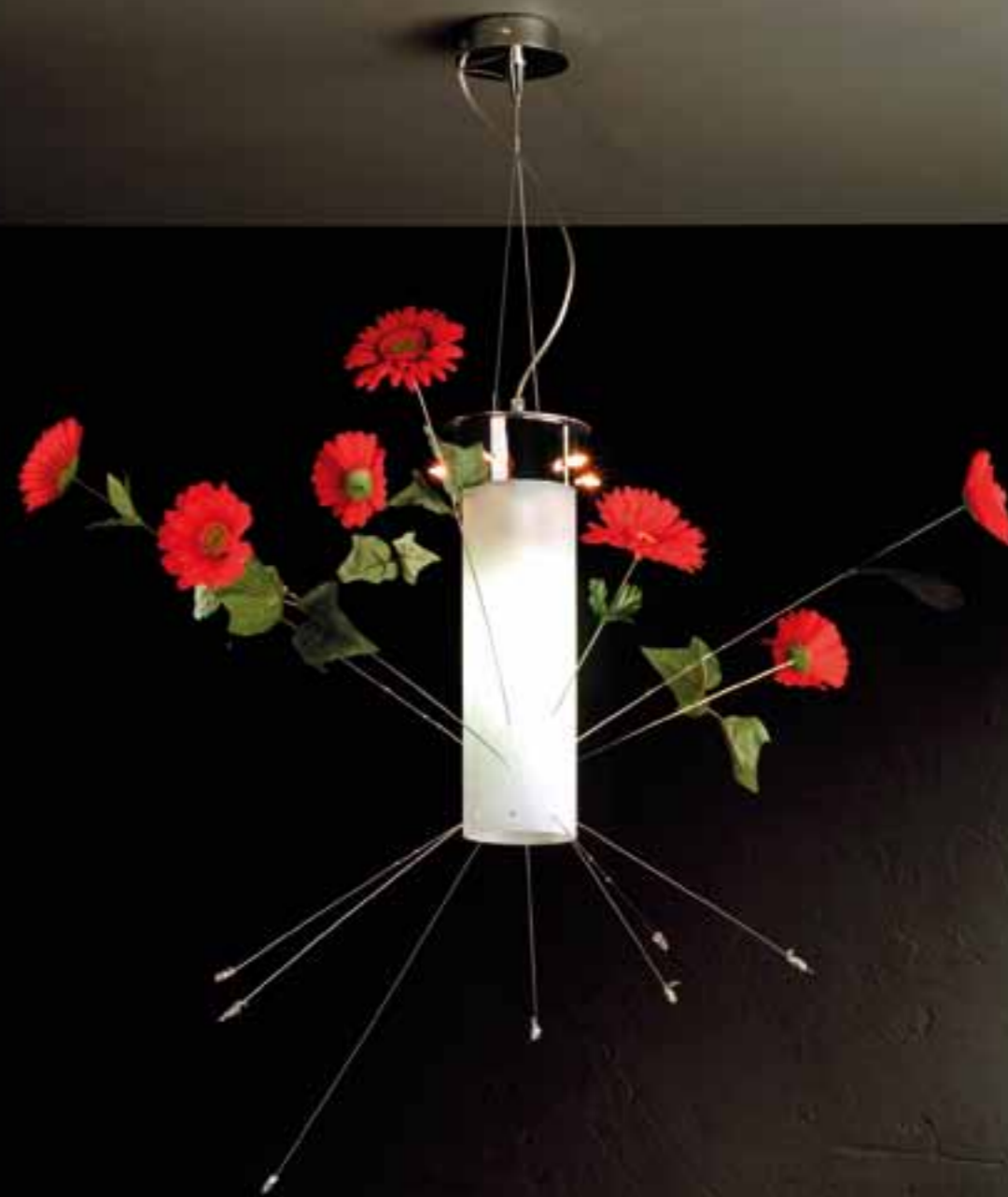

Cod. 7517

FLOWERS

5 x 20W MAX  
 G4 230/12V

1 x 23W  
 E27 230V FBT

CE IP20

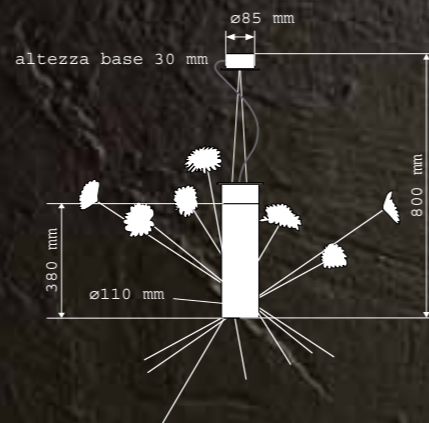

ELLE EST TOUJOURS FLEURIE.  
 ESTÁ SIEMPRE FLORECIDO.

E' SEMPRE FIORITO.  
 IT'S ALWAYS IN FLOWER.

FLOWERS \_143  
 ORELLI  
 LUCIANO





Base: Metallo  
 Stelo: Rame  
 Finitura: Verniciatura Nera (VN)  
 Opzioni: Cromo (CR) Zincatura Bianca (ZB)  
 Gialla (ZG) Verniciatura Bianca (VB)  
 Particolarità: Steli modellabili e pendagli  
 Lampadina: Colpo di vento  
 Peso e misure con imballo:  
 10 kg - 480 x 490 x 1.150 mm

Base: Metal  
 Stem: Copper  
 Finish: Painted Black (VN)  
 Options: Chrome (CR), Galvanized White (ZB),  
 Yellow (ZG), White Paint (VB)  
 Detail: Mouldable stems and pendant  
 Lamp: Gust of wind  
 Weight and Measurements including Packaging:  
 10 kg - 480 x 490 x 1.150 mm

Base: Métal  
 Tiges: Cuivre  
 Finition: Peinture Noire (VN)  
 Options: Chrome (CR), Zingage Blanc (ZB),  
 jaune (ZG), Peinture Blanche (VB)  
 Particularité: Tiges modelables, pendants  
 Ampoule: Coup de vente  
 Poids et mesures avec emballage:  
 10 kg - 480 x 490 x 1.150 mm

Base: Metal  
 Tubo: Cobre  
 Acabado: Barnizado Negro (VN)  
 Opciones: Cromo (CR) Galvanizado con Zinc en  
 Blanco (ZB) Amarillo (zg) Barnizado Blanco (VB)  
 Particularidades: Tubos moldeables y colgantes  
 Bombilla: Golpe de viento  
 Peso y medidas con embalaje:  
 10 kg - 480 x 490 x 1.150 mm

**Cod. 7519 VN**

OPZIONI: (CR) (ZB) (ZG) (VB)

TOQUÌ

12 x 40W MAX  
 E14 230V



CE IP20

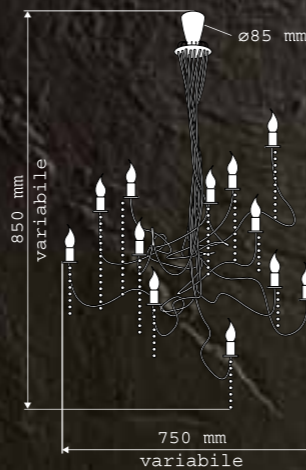

TOQUÌ BLACK \_145

LA PIÈCE N'À PLUS DE MURS.  
 LA HABITACIÓN YA NO TIENE PAREDES.

LA STANZA NON HA PIÙ PARETI.  
 THE ROOM NO LONGER HAS WALLS.

TOQUÌ  
 LUCIFERO  
 LUCIFERO





Cod. 7521

ACQUARIUM

14 x 20W MAX  
G4 230/12V

1 x 20W MAX Ø35  
GU4 230/12V

CE IP20



Base: Metallo spazzolato  
Stelo: Rame  
Finitura: Zincatura bianca  
Particolarità: Pesci fuor d'acqua, finitura silico-  
nica sui pesci  
Trasformatore: Toroidale inserito nella base  
Lampadina: Alogena bispina + dicroica  
Peso e misure con imballo:  
13 kg - 750 x 460 x 560 mm

Base: Brushed metal  
Stem: Copper  
Finish: White galvanized  
Detail: Fish out of water, silicone finish on fish  
Transformer: Toroidal within the base  
Lamp: Double plug-in halogen + dichroic  
Weight and Measurements including Packaging:  
13 kg - 750 x 460 x 560 mm

Base: Métal brossé  
Tiges: Cuivre  
Finition: Zingage Blanc  
Particularité: Poissons hors de l'eau, finition  
silicone sur les poissons  
Transformateur: Toroidal inséré dans la base  
Ampoule: Halogène bi-pin + dichroïque  
Poids et mesures avec emballage:  
13 kg - 750 x 460 x 560 mm

Base: Metal cepillado  
Tubo: Cobre  
Acabado: Galvanizado con Zinc blanca  
Particularidades: Peces fuera del agua, Acaba-  
do con silicona en los peces  
Transformador: Toroidal introducido en la base  
Bombilla: Halógena doble enchufe + dicroica  
Peso y medidas con embalaje:  
13 kg - 750 x 460 x 560 mm

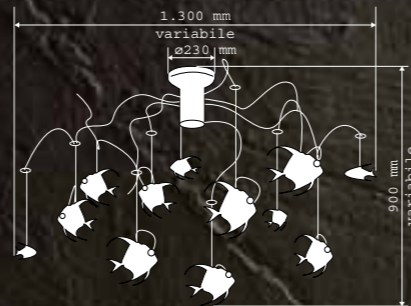

UN PESCE NON FA PRIMAVERA  
PENSA L'UOMO MUTO COME UNA RONDINE  
MENTRE UNO STORMO DI PESCI VOLA SUL SOFFITTO  
E UN BRANCO DI RONDINI RISALE LA CORRENTE.  
ARIA E ACQUA PRENDONO LA FORMA DELLA STANZA  
E LA LUCE È LA STESSA.  
A CAPOVOLGERE LA LOGICA DEI FLUIDI  
L'UOMO ACCENDE L'OCEANO.

ONE FISH DOESN'T MAKE A SUMMER  
THINK OF MAN MUTE LIKE A SWALLOW  
WHILE A FLOCK OF FISH FLIES ONTO THE CEILING.  
AND A SHOAL OF SWALLOWS GOES UP STREAM  
AIR AND WATER TAKE THE FORM OF THE ROOM  
AND THE LIGHT DOES THE SAME.  
TURNING THE LOGIC OF FLUIDS ON ITS HEAD.  
MAN TURNS ON THE OCEAN.

UN POISSON NE FAIT PAS LE PRINTEMPS PENSE  
L'HOMME MUET COMME UNE HIRONDELLE ALORS  
QU'UNE NUÉE DE POISSONS VOLE SUR LE PLAFOND  
ET UN BANC D'HIRONDELLES REMONTE LE COURANT.  
AIR ET EAU PRENNENT LA FORME DE LA PIÈCE ET LA  
LUMIÈRE DE MÊME.  
POUR BOULEVERSER LA LOGIQUE DES FLUIDES  
L'HOMME ALLUME L'OcéAN.

CON UN SOLO PEZ NO HA LLEGADO LA PRIMAVERA  
PIENSA EL HOMBRE MUDDO COMO UNA GOLONDRINA  
MIENTRAS UNA BANDADA DE PECES VUELA EN EL  
TECHO Y UNA MANADA DE GAVIOTAS SUBE POR LA  
CORRIENTE. AIRE Y AGUA TOMAN LA FORMA DE LA  
HABITACIÓN Y LA LUZ ES LA MISMA.  
A INVERTIR LA LÓGICA DE LOS FLUIDOS  
EL HOMBRE ENCIENDE EL OCEANO.



ACQUARIUM 147



## PECCATI DI LUCE

Adamo ed Eva. Il frutto proibito. Il peccato originale. Dal paradiso terrestre, due nuove creazioni dedicate al giardino per un viaggio tra tentazioni, design, creatività. Luce/ombra, angeli/demoni, dualità in armonia: da sempre il regno di Lucifero.

**STRUTTURA:** ACCIAIO CORTEN  
**FIGURA:** DOPPIA COMPONENTE SU TELAIO IN METALLO SCATOLATO  
**BASE:** TUBO ALTEZZA 1.200 MM (DI CUI 800 MM INTERRATO)  
**PARTICOLARITÀ:** ARRUGGINIMENTO NATURALE ALLE INTEMPERIE

**Cod. 9702**

A D A M O

**Cod. 9703**

E V A

FARETTI C/LAMPADA  
IODURI METALLICI  
3x35W  
GX 10 230V 

CE IP65  

ALIMENTATORI INSERITI  
NEL CILINDRO FARETTI

PESO E MISURE CON IMBALLO ADAMO:  
146 KG - 2.270 x 400 x 1100 MM  
540 x 540 x 620 MM

PESO E MISURE CON IMBALLO EVA:  
101 KG - 2.270 x 400 x 750 MM  
540 x 540 x 620 MM



## SINS OF LIGHT

Adam and Eve. The forbidden fruit. The original sin. From an earthly paradise, two new creations dedicated to the garden for a journey between temptations, design and creativity. Light/Shadow, Angels/Demons, a dual of harmony: forever the realm of Lucifer.

**STRUCTURE:** CORTEN STEEL  
**FORM:** NO 2 SECTIONAL BODIES ON BOX TYPE METAL FRAME  
**BASE:** PIPE, TOTAL HEIGHT 1.200 MM (OF WHICH 800 MM UNDERGROUND)  
**DETAIL:** NATURAL RUSTING THROUGH WEATHERING

**Cod. 9702**

A D A M O

**Cod. 9703**

E V A

SPOT LIGHTS WITH  
METALLIC IODIDE BULB  
3x35W  
GX 10 230V 

CE IP65  

POWER SUPPLY WITHIN  
THE SPOTLIGHT CYLINDER

WEIGHT AND MEASUREMENTS INCLUDING  
PACKAGING FOR ADAMO:  
146 KG - 2.270 x 400 x 1100 MM  
540 x 540 x 620 MM

WEIGHT AND MEASUREMENTS INCLUDING  
PACKAGING FOR EVA:  
101 KG - 2.270 x 400 x 750 MM  
540 x 540 x 620 MM

ADAMO

EVA

LUCIFERO  
LUCIFERO





Cod. 9700 (TERRA)

1 x 23W E27 FBT 230V  
C/LAMPADA A RISPARMIO ENERGETICO



MATERIALE: POLIPROPILENE  
ADATTATORE PER PALO Ø 60MM  
FORNITO SENZA PALO

PESO E MISURE CON IMBALLO:  
6 KG - 1.150 X 300 X 490 MM  
WEIGHT AND MEASUREMENTS INCLUDING PACKAGING:  
6 KG - 1.150 X 300 X 490 MM

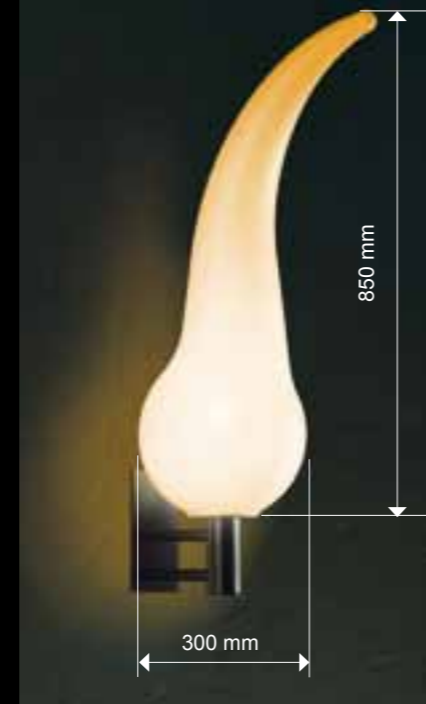

Cod. 9701 (PARETE)

1 x 23W E27 FBT 230V  
C/LAMPADA A RISPARMIO ENERGETICO

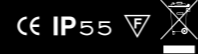

MATERIALE: POLIPROPILENE  
STAFFA: INGOMBRO 30 CM  
PESO E MISURE CON IMBALLO:  
7,5 KG - 1.150 X 300 X 490 MM  
WEIGHT AND MEASUREMENTS INCLUDING PACKAGING:  
7,5 KG - 1.150 X 300 X 490 MM



Casa Privata  
Private House



Casa Privata  
Private House



LUCIFERO ILLUMINA I VOSTRI GIARDINI



Casa Obert (Bed & Breakfast)



Villa Maggiorana



Villa Gualino

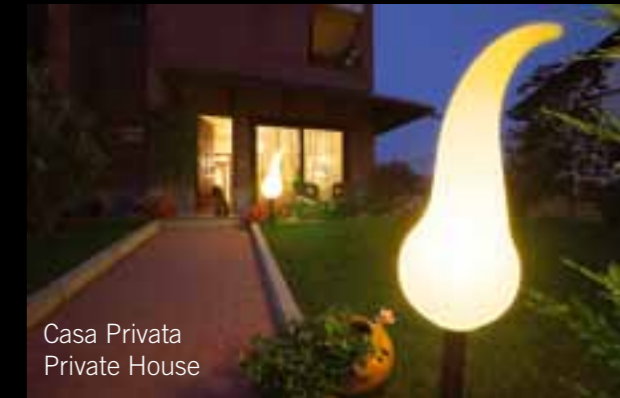

Casa Privata  
Private House









**LA CENA E PRONTA**

Cod. 75 I 4N ZB (ZINCATURA BIANCA)  
Cod. 75 I 4N ZG (ZINCATURA GIALLA)

C/BISPINA 1 2 x 20W MAX G4 230/1 2V CE IP20

PESO E MISURE CON IMBALLO: 17 KG - 2.150 x 360 x 470 MM  
WEIGHT AND MEASUREMENTS INCLUDING PACKAGING: 17 KG - 2.150 x 360 x 470 MM



Agriturismo Casa Oberth



**SERVITO**

Cod. 6026

C/LAMPADA COLPO DI VENTO 2 x 40W (60W MAX)

E14 230V CE IP20

PESO E MISURE CON IMBALLO / WEIGHT AND MEASUREMENTS INCLUDING PACKAGING: 3,2 KG - 500 x 410 x 250 MM



**TÊTÊ A TÊTÊ**

Cod. 6025

C/LAMPADA COLPO DI VENTO 2 x 40W (60W MAX)

E14 230V CE IP20

PESO E MISURE CON IMBALLO / WEIGHT AND MEASUREMENTS INCLUDING PACKAGING: 3,2 KG - 500 x 410 x 250 MM



LUCIFERO e PISTOLETTO

Installazione: "la tavola imbandita" - città dell'arte  
Installation: "the laid table"

LUCIFERO PISTOLETTO



S I S T E M A T O T A M

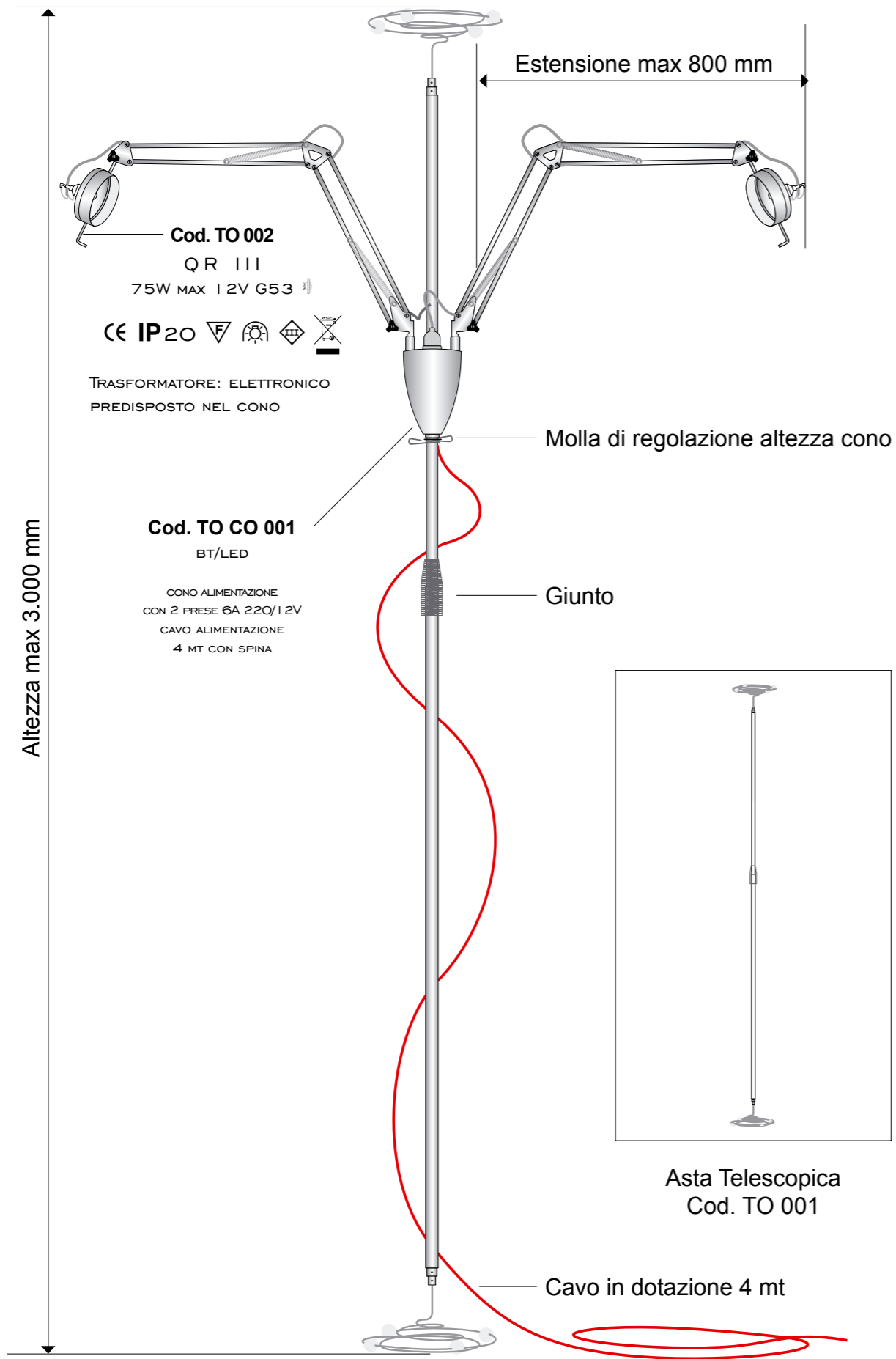

T O T A M S Y S T E M

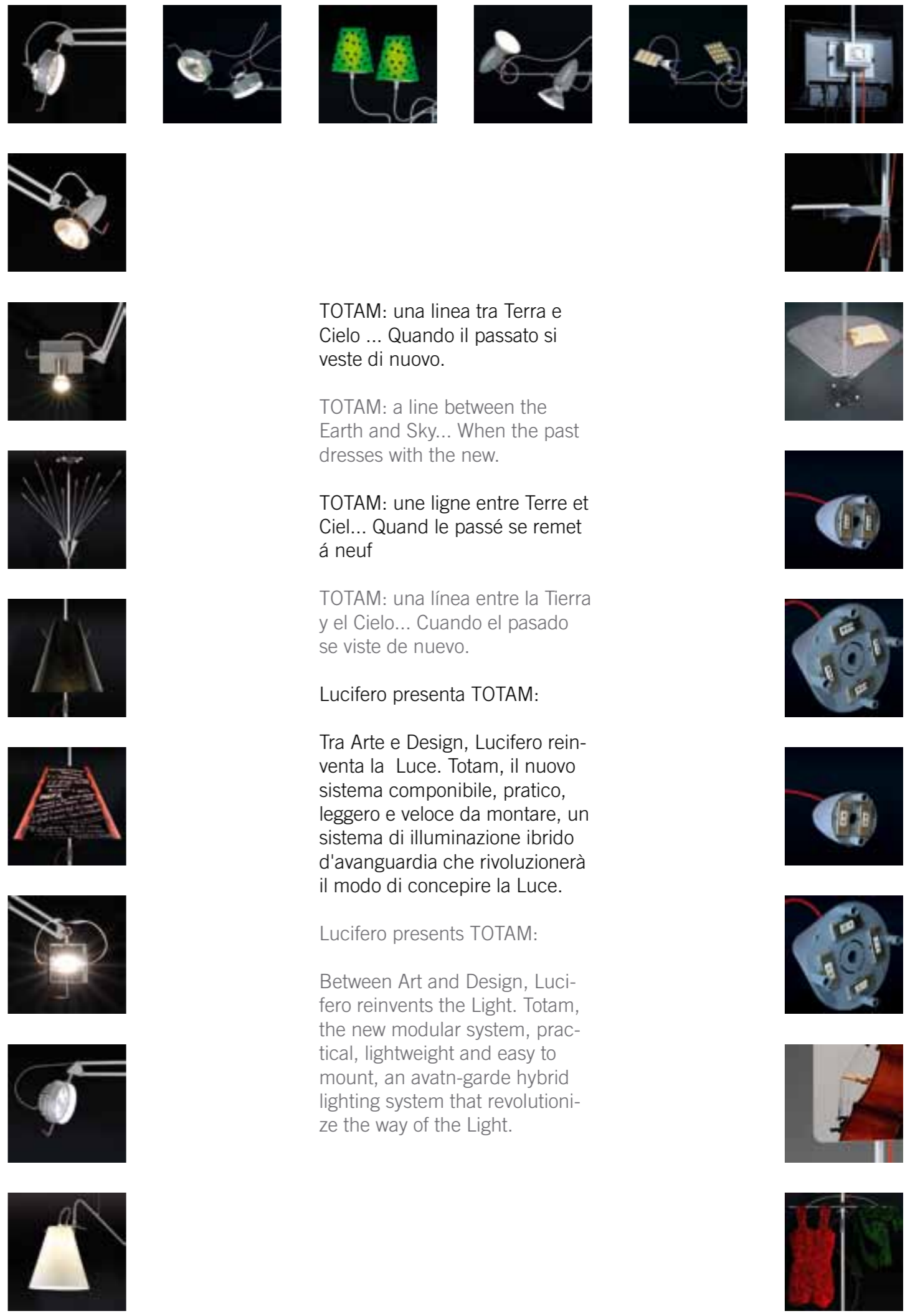

TOTAM: una linea tra Terra e Cielo ... Quando il passato si veste di nuovo.

TOTAM: a line between the Earth and Sky... When the past dresses with the new.

TOTAM: une ligne entre Terre et Ciel... Quand le passé se remet á neuf

TOTAM: una línea entre la Tierra y el Cielo... Cuando el pasado se viste de nuevo.

Lucifero presenta TOTAM:

Tra Arte e Design, Lucifero reinventa la Luce. Totam, il nuovo sistema componibile, pratico, leggero e veloce da montare, un sistema di illuminazione ibrido d'avanguardia che rivoluzionerà il modo di concepire la Luce.

Lucifero presents TOTAM:

Between Art and Design, Lucifero reinvents the Light. Totam, the new modular system, practical, lightweight and easy to mount, an avatn-garde hybrid lighting system that revolutionize the way of the Light.





**Cod. TO 004**  
MIRROR

LARGHEZZA 400MM  
ALTEZZA 1.100 MM  
WIDTH 400MM  
HEIGHT 1.100 MM

S I S T E M A T O T A M



**Cod. TO 002**

QR III  
75W MAX 12V G53



TRASFORMATORE: ELETTRONICO  
PREDISPOSTO NEL CONO



**Cod. TO 003**

PAR  
75W MAX E27 PAR 30  
220-240V



T O T A M S Y S T E M



**Cod. TO 005**

JM  
20W MAX GX10 220-240V

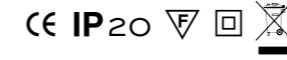

ALIMENTATORE ELETTRONICO  
INSERITO NEL CORPO LAMPADA



**Cod. TO 007**

STAR  
12x20W MAX G4 BISPINA  
220-240V/12V

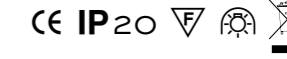

N.2 TRASFORMATORI ELETTRO-  
NICI INSERITI NEL CONO

159



**Cod. TO CO 001**

BT/LED  
CONO ALIMENTAZIONE CON 2 PRESE 6A  
CAVO ALIMENTAZIONE 4 MT CON SPINA



**Cod. TO CO 003**

CONO ALIMENTAZIONE CON 2 PRESE 10A  
CAVO ALIMENTAZIONE 4 MT CON SPINA



**Cod. TO 006**

R7s  
150W MAX R7s  
220-240V

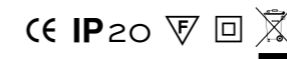

**Cod. TO CO 003**

CONO ALIMENTAZIONE CON 2 PRESE 10A  
CAVO ALIMENTAZIONE 4 MT CON SPINA





S I S T E M A

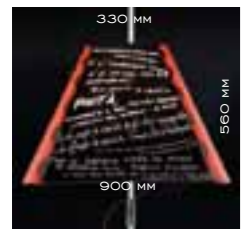

**Cod. TO 008**  
VA NR  
3x23W E27 FBT  
220-240V

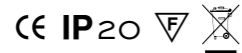

CONO IN POLIPROPILENE



**Cod. TO 008/1**  
VA WHITE  
3x23W E27 FBT  
220-240V

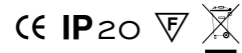

CONO IN POLIPROPILENE



**Cod. TO 008/2**  
VA RN  
3x23W E27 FBT  
220-240V



CONO IN POLIPROPILENE

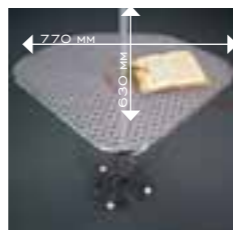

**Cod. TO 010**  
TABLE  
TAVOLO IN POLICARBONATO  
TRASPARENTE  
DIMENSIONI  
LARGHEZZA 770 x 630 MM

T O T A M



**Cod. TO 009**  
CN BLACK  
2x23W E27 FBT  
220-240V



CONO IN POLIPROPILENE

OPZIONE CODICE:

TO 009/1 (CN WHITE)  
TO 009/2 (CN RED)

S Y S T E M



**Cod. TO 011**  
STAF

STAFFA IN METALLO VERNICIATO CON 2 PRESE 10A 220/240V E CAVO ALIMENTAZIONE 4 MT CON SPINA PER MONITOR LCD MAX 20"



**Cod. TO 012**  
BASE

BASE PER PLAYER MULTIMEDIALE O LETTORE DVD IN METALLO VERNICIATO





**Cod. TO 014**  
APP  
APPENDIABITI  
COAT HANGER

S I S T E M A



**Cod. TO 013**  
LED  
LED 9W 350mA (6.000°K)  
220-240V  
CE IP20

ALIMENTATORE PREDISPOSTO  
NEL CONO



**Cod. TO 003**  
PAR  
75W MAX E27 PAR 30  
220-240V  
CE IP20



**Cod. TO CO 001**  
BT/LED  
CONO ALIMENTAZIONE CON 2 PRESE 6A  
CAVO ALIMENTAZIONE 4 MT CON SPINA  
220-240/12V  
CE IP20



**Cod. TO CO 003**  
CONO ALIMENTAZIONE CON 2 PRESE 10A  
CAVO ALIMENTAZIONE 4 MT CON SPINA  
220-240V  
CE IP20

T O T A M S Y S T E M



**Cod. TO 015**  
PLUS  
23W E27 FBT  
220-240V  
CE IP20

CONO IN POLIPROPILENE BIANCO



**Cod. TO CO 004**  
CONO ALIMENTAZIONE CON 4 PRESE 10A  
CAVO ALIMENTAZIONE 4 MT CON SPINA  
220-240V  
CE IP20



**Cod. TO CO 002**  
BT/LED  
CONO ALIMENTAZIONE CON 4 PRESE 6A  
CAVO ALIMENTAZIONE 4 MT CON SPINA  
220-240/12V  
CE IP20





S I S T E M A T O T A M T O T A M S Y S T E M



**Cod. TO 016**  
QR III  
4 x 75W MAX 12V  
G53 220-240V



TRASFORMATORI ELETTRONICI  
INSERITI NEL CONO



**Cod. TO 017**  
LU  
5 x 40W MAX E14  
220-240V

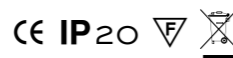

OPZIONE COLORE:  
RED, GREEN, BLUE, YELLOW



**Cod. TO 018**  
PAR  
4 x 75W MAX E27 PAR 30  
220-240V



**Cod. TO 019**  
PLANA LED  
4 x 11W 12V (6.000°K)  
220-240V

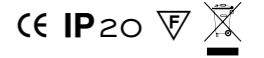

TRASFORMATORE TOROIDALE  
INSERITO NEL CONO







IL VINO BUONO STA NELLA BOTTE PICCOLA.  
A GOOD WINE FITS IN A SMALL KEG.

LE BON VIN SE TROUVE DANS LE PETIT TONNEAU.  
EL BUEN PERFUME SE GUARDA EN FRASCO PEQUEÑO.



**L E D**

**L E D**

**Cod. LED TA 001**  
**CHIBADOS**  
LED 4W 350mA (6.000°K)  
220-240V  
CE IP20   



ALIMENTATORE A SPINA

**Cod. 2500 LED**  
**LEDAIR**  
LED 11W 12V (6.000°K)  
220-240V  
CE IP20   

**Cod. LED AP 003**  
**HAYE**  
LED 2x4W 350 mA (6.000°K)  
220-240V  
CE IP20  



**Cod. LED AP 002**  
**FIREFAX**  
LED 4W 350 MA (6.000°K)  
220-240V  
CE IP20   

COLORI INSERTI PLEXIGLAS  
    
(INTERASSE FORI FISSAGGIO PER 503)

**Cod. LED SO 001**  
**TUBELED**  
LED 4W E27 (6.000°K)  
220-240V  
CE IP20  

**Cod. LED AP 001**  
**DAHUT**  
LED 11W 12V (6.000°K)  
220-240V  
CE IP20  

TRASFORMATORE TOROIDALE  
INSERITO NELLA BASE

**Cod. LED TA 002**  
**YEXA**  
LED 0,8W  
220-240V  
CE IP20   





Casa Privata  
Private House



Casa Privata  
Private House



Sinergia - Torino.



Casa Privata  
Private House



Sinergia di Torino.



Uffici della ditta Sinergia di Torino - Energia e telecomunicazioni.



Villa Tiboldi.



Villa Tiboldi.



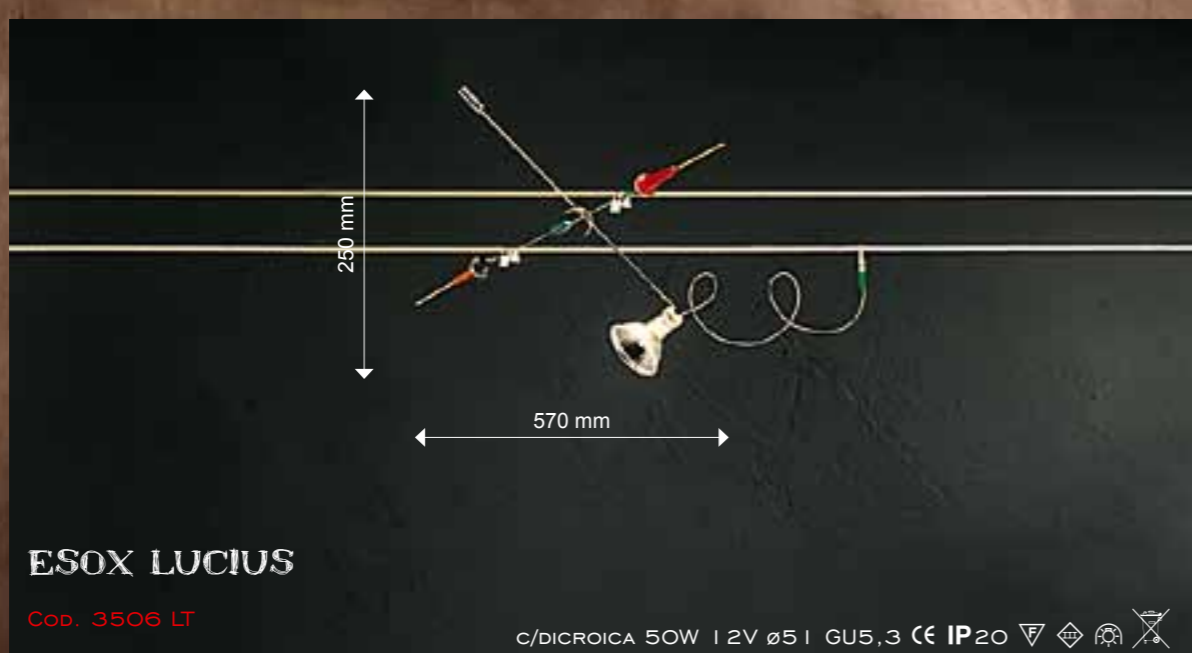
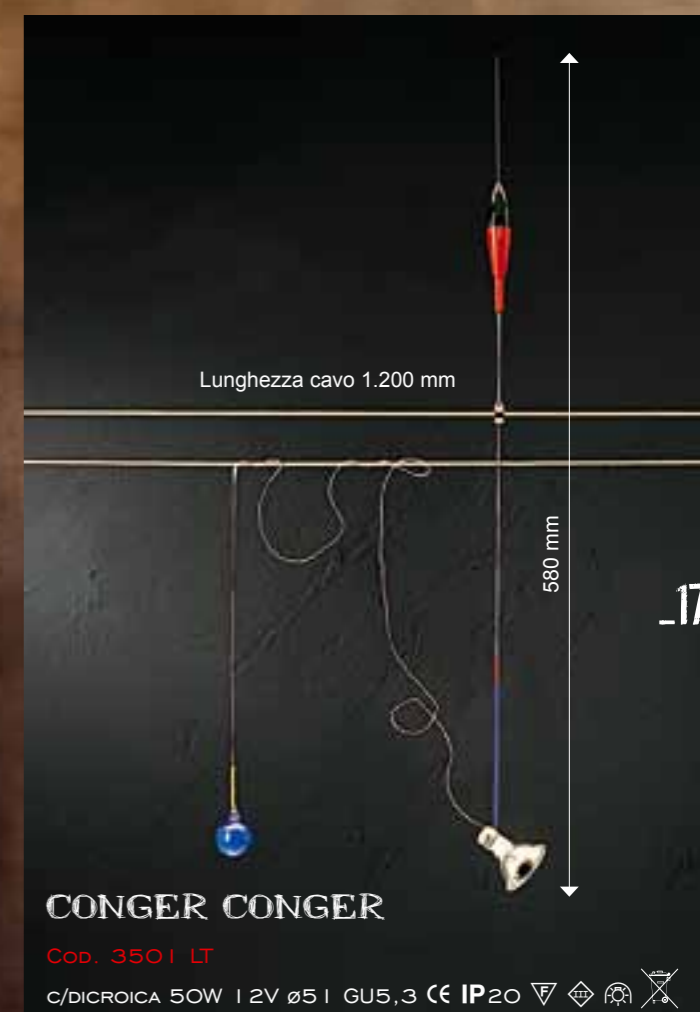
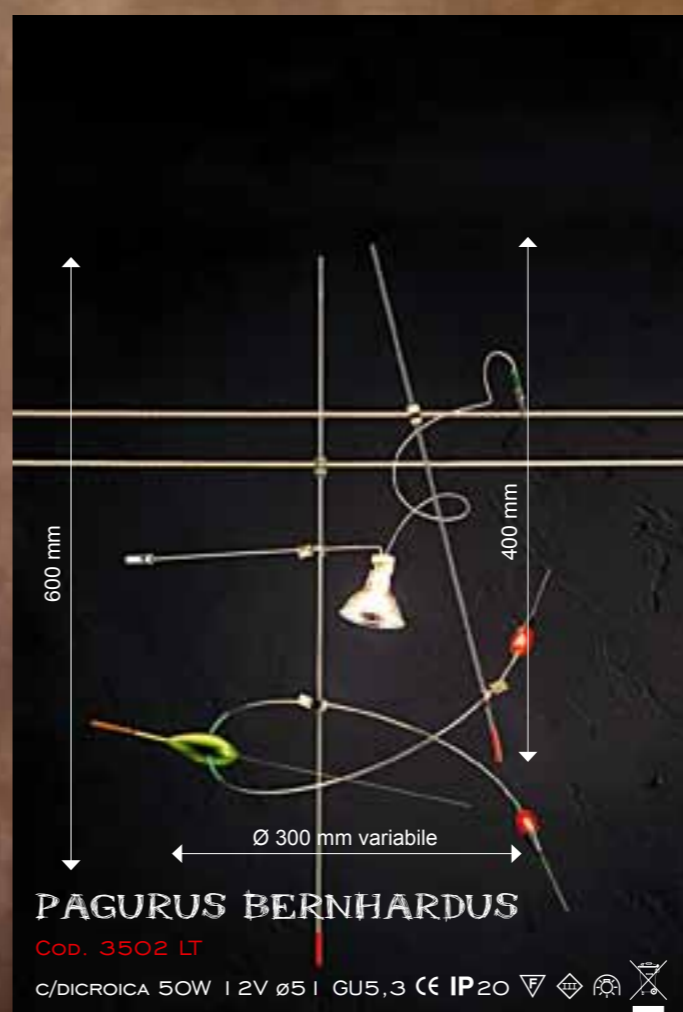
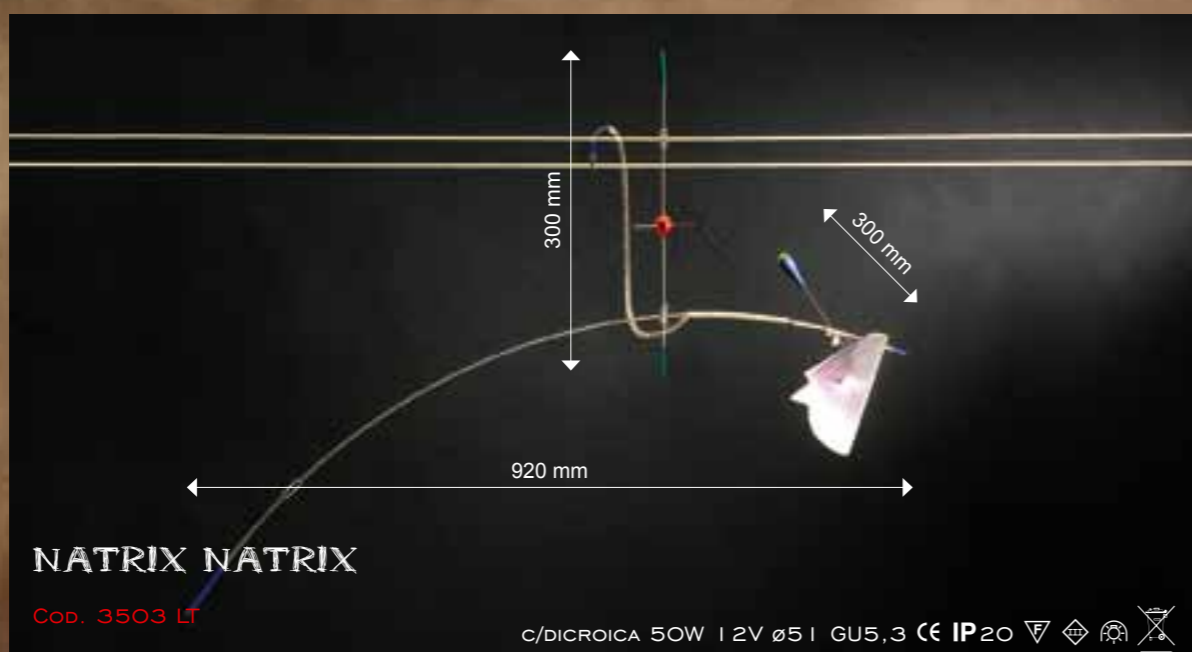
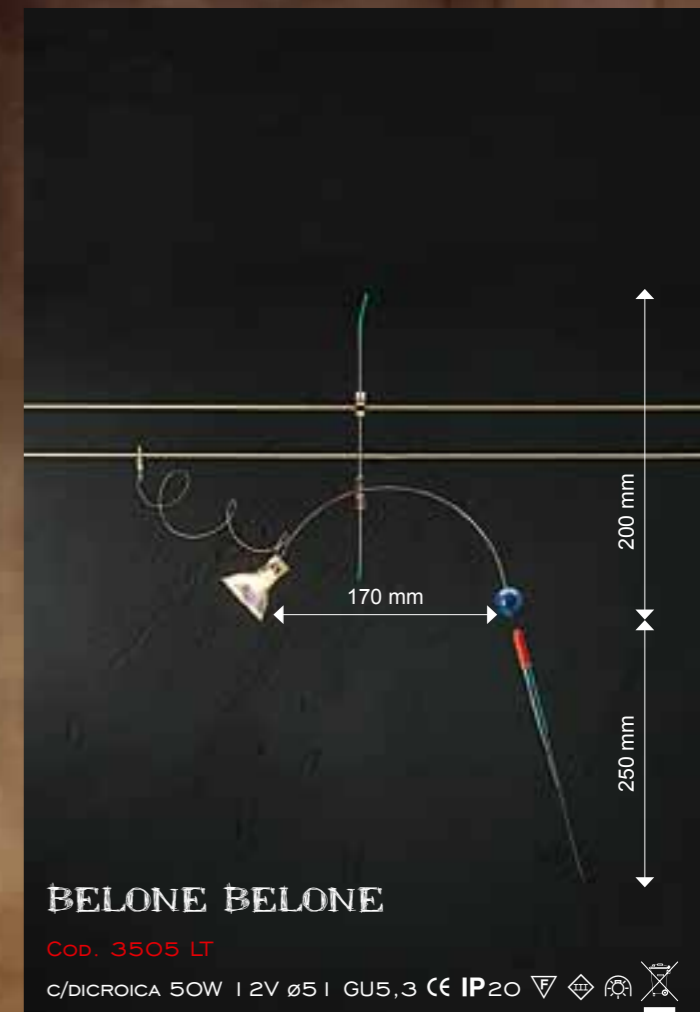
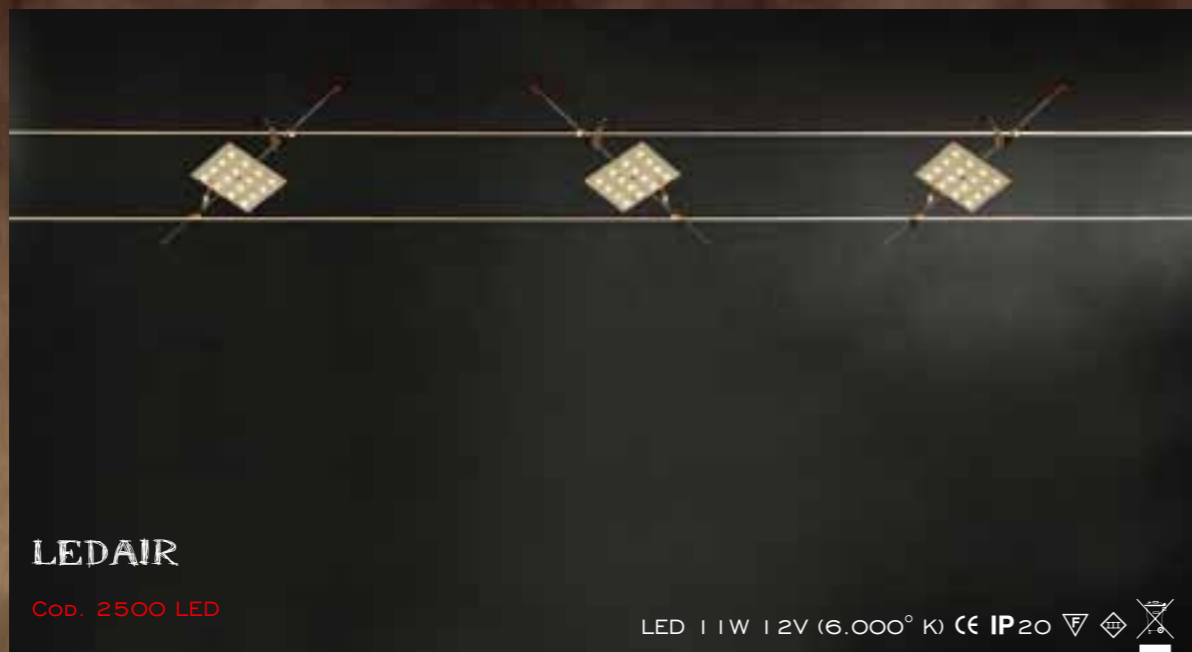



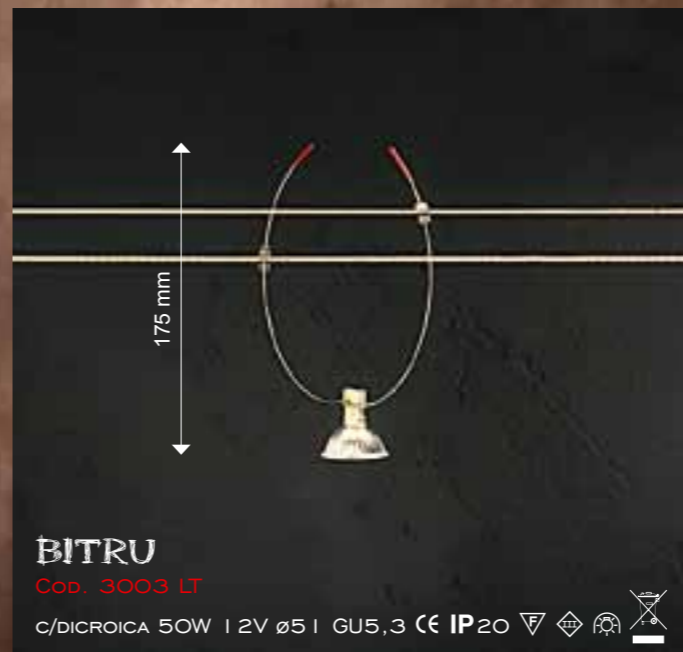
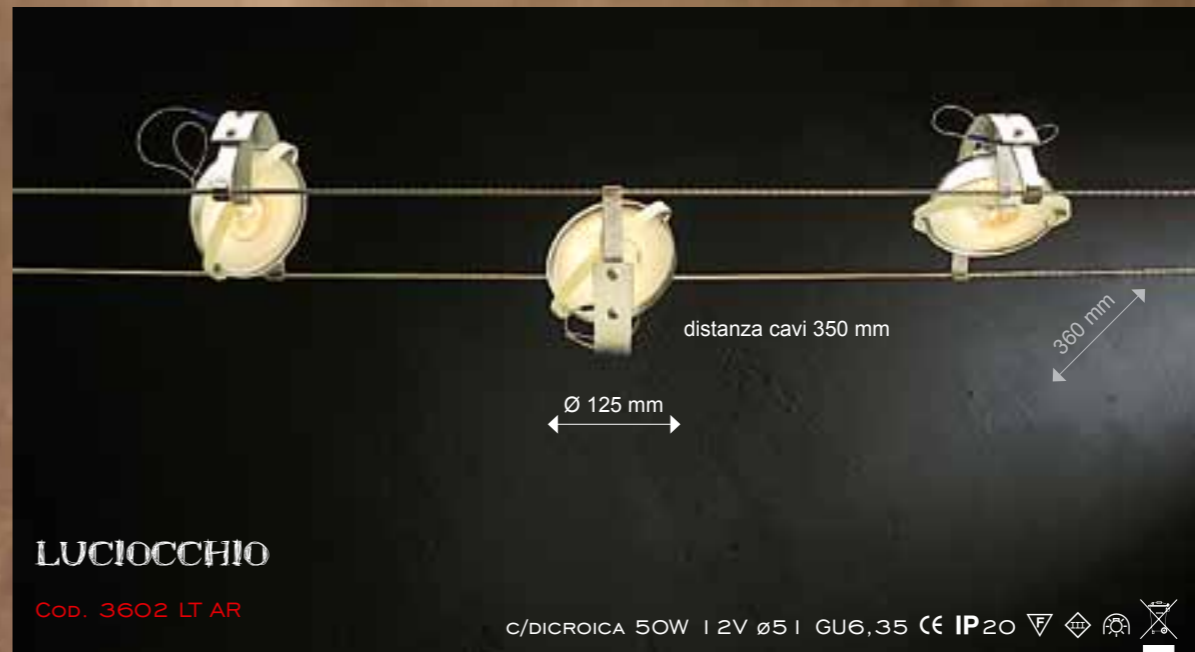
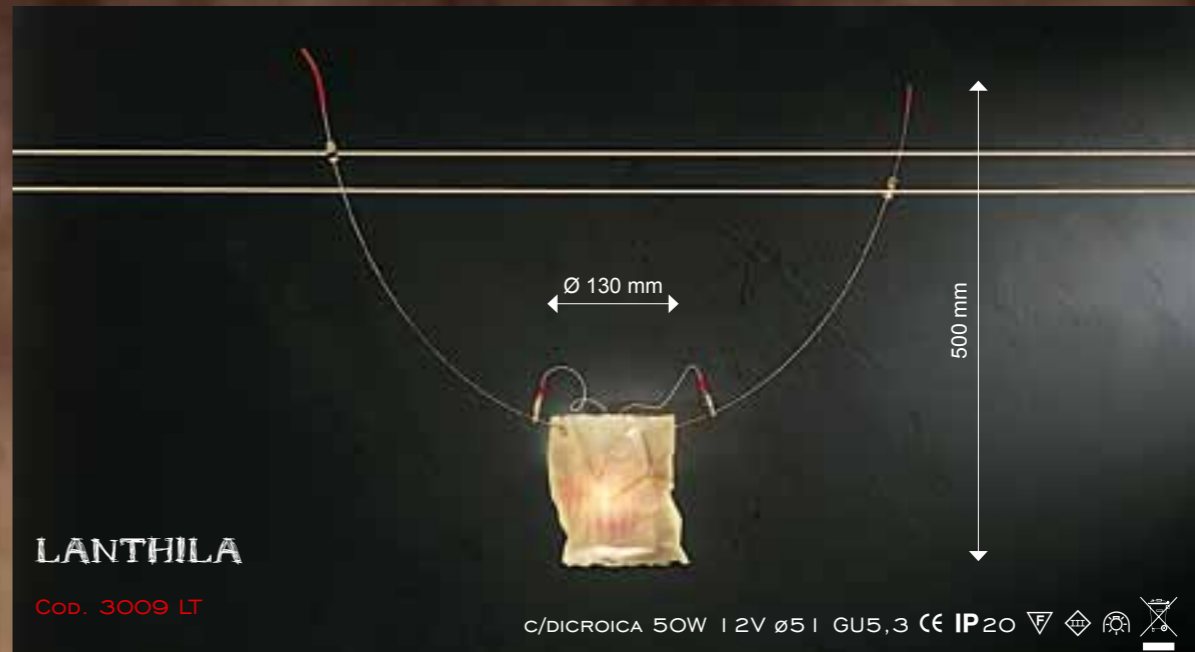



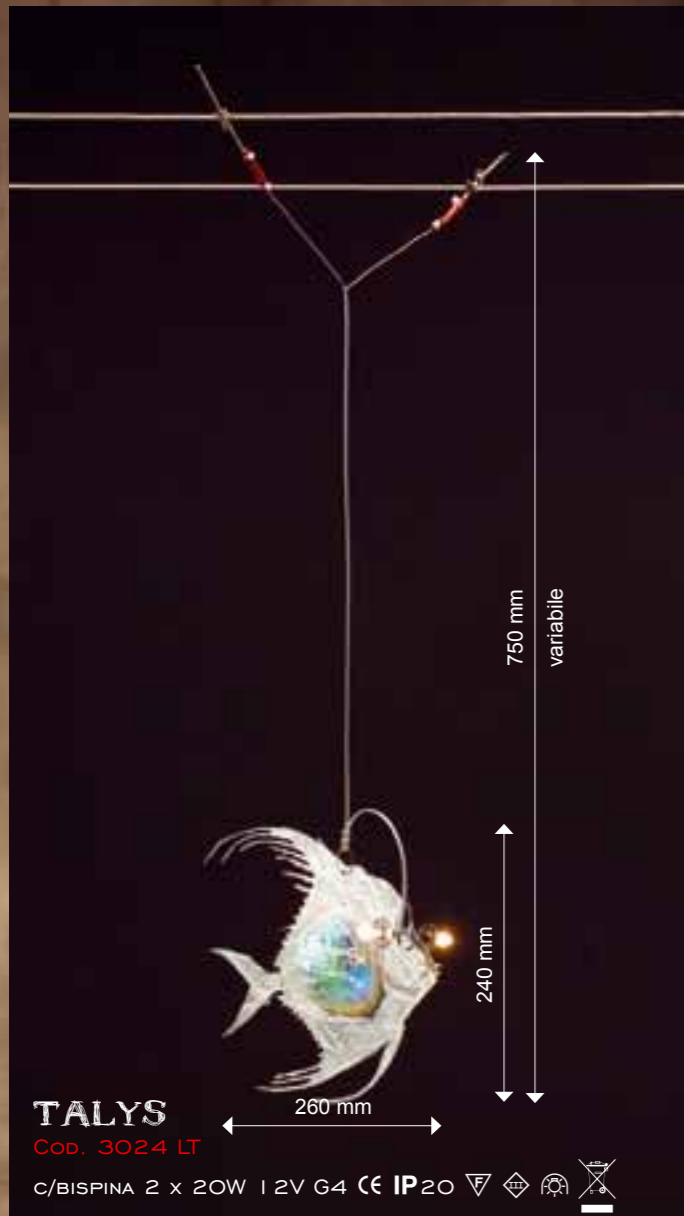

**TALYS**  
Cod. 3024 LT

750 mm  
variabile

240 mm

260 mm

C/BISPINA 2 x 20W | 2V G4 CE IP20



**OES**  
Cod. 3025 LT

1.000 mm  
variabile

C/BISPINA 5 x 10W G4 | 2V CE IP20

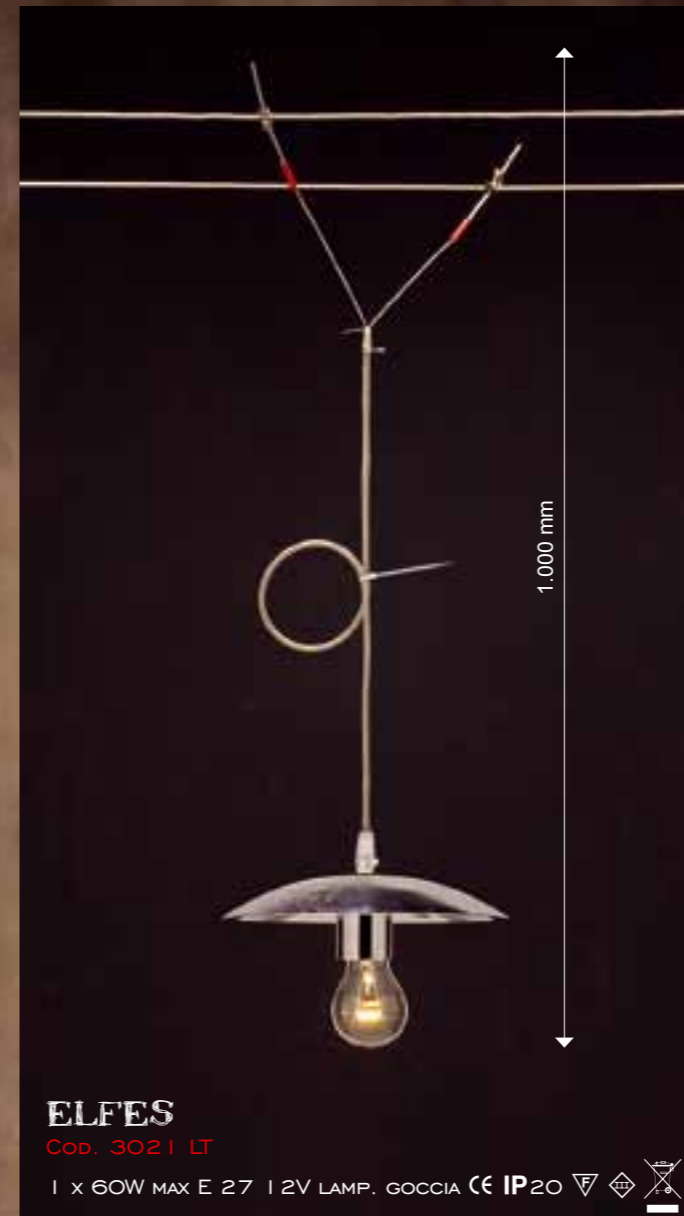

**ELFES**  
Cod. 3021 LT

1.000 mm

1 x 60W MAX E 27 | 2V LAMP. GOCCIA CE IP20



**SALEH**  
Cod. 3020 LT

1.200 mm

1 x 60W MAX E 27 | 2V LAMP. GOCCIA CE IP20

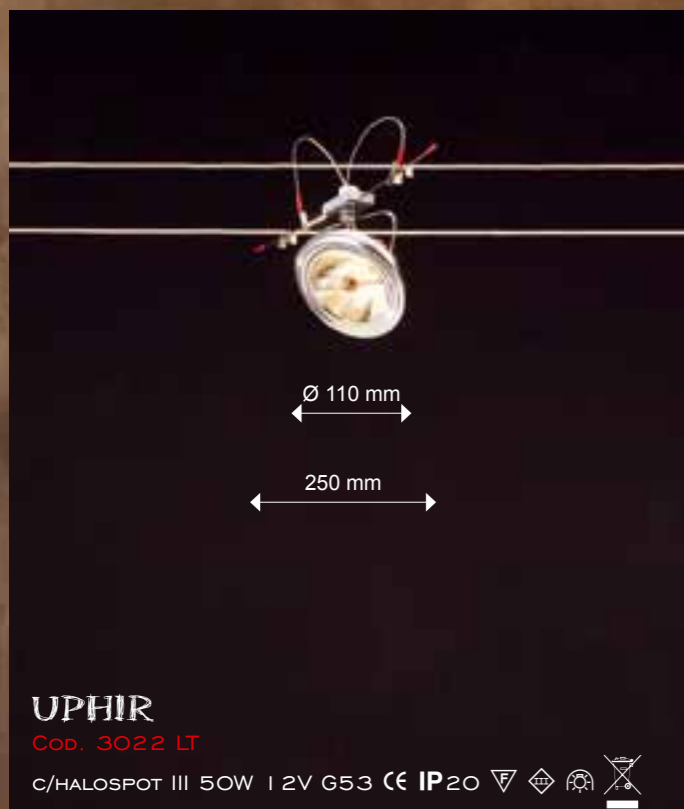

**UPHIR**  
Cod. 3022 LT

Ø 110 mm

250 mm

C/HALOSPOT III 50W | 2V G53 CE IP20

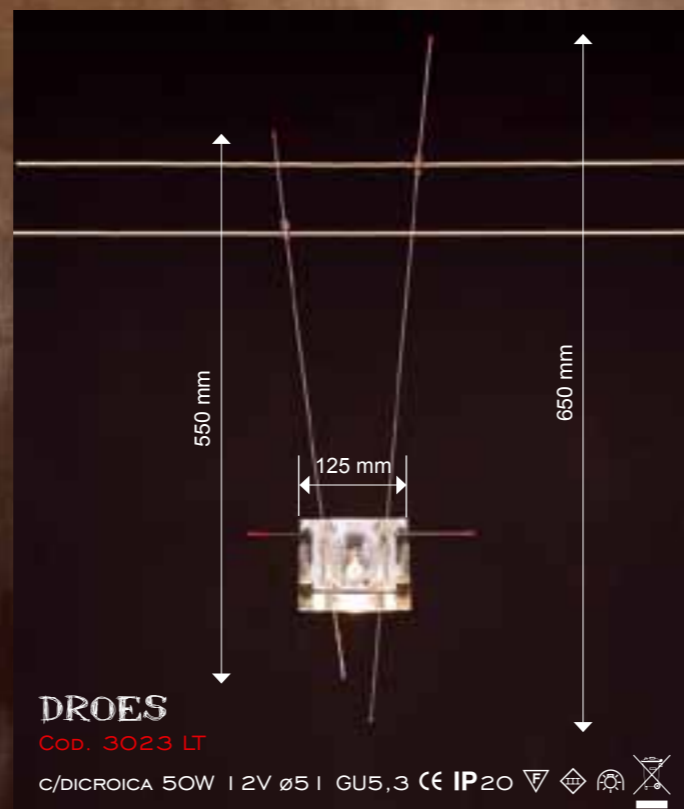

**DROES**  
Cod. 3023 LT

550 mm

125 mm

650 mm

C/DICROICA 50W | 2V Ø5 | GU5,3 CE IP20



**HEBEN**  
Cod. 3018 LT

500 mm

C/HALOSPOT III 50W | 2V G53 CE IP20



**NIHA**  
Cod. 3019 LT

200 mm

175

1 x 60W MAX E 27 | 2V LAMP. GOCCIA CE IP20



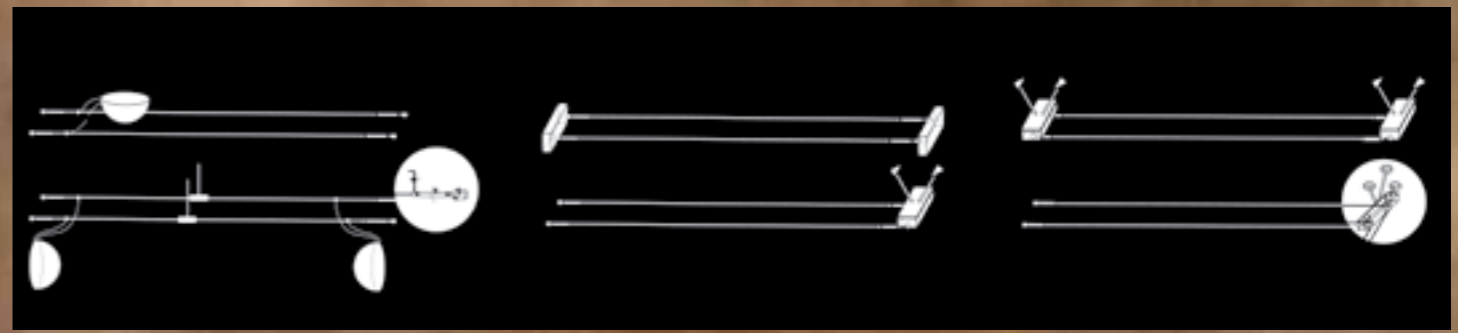
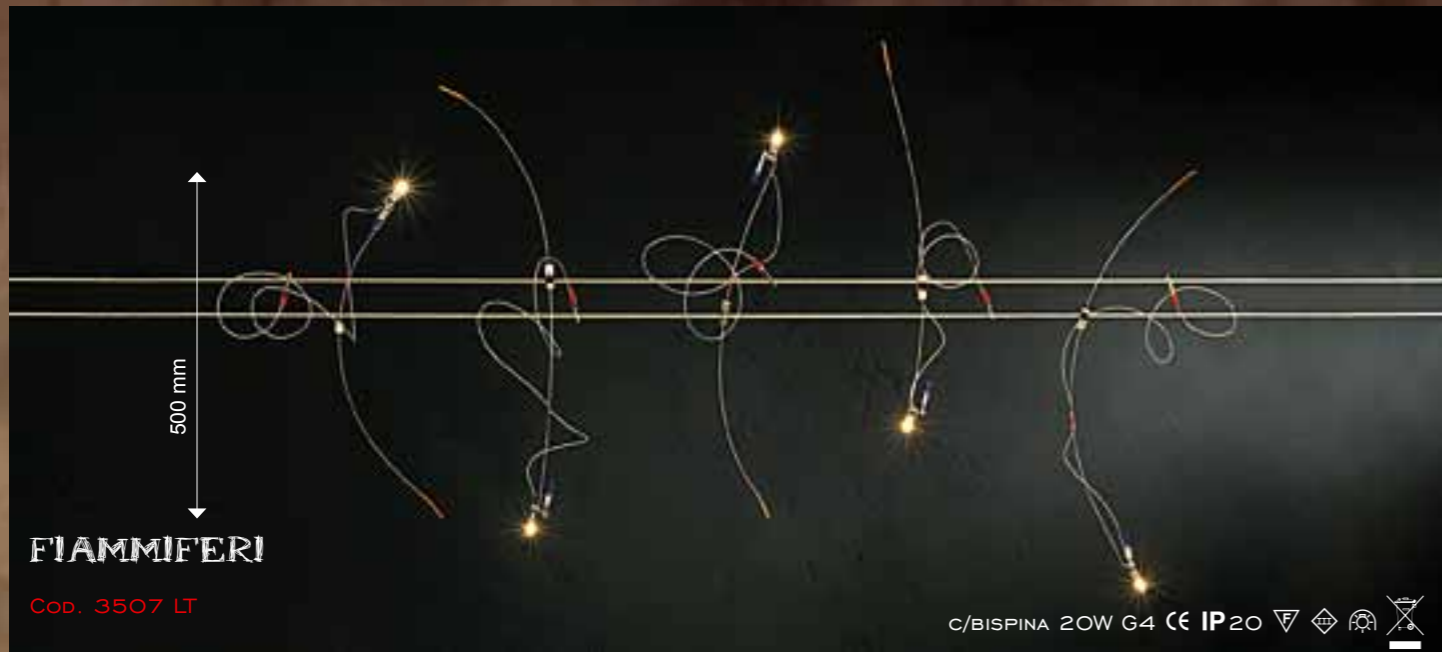

**COMPONENTI PER SISTEMA BASSA TENSIONE 12V**







**SISTEMA COLOMBO 220/240V**

**COLOMBO SYSTEM 220/240V**



CAVO ALIMENTAZIONE  
LINE CORD

OVO PRELEVA TENSIONE  
FEEDING EGG

CAVI ACCIAIO  
STEEL CABLE

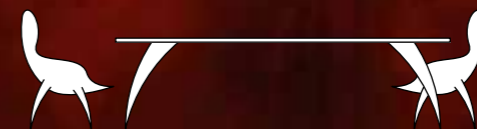
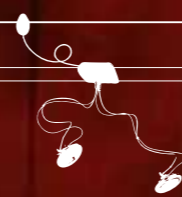



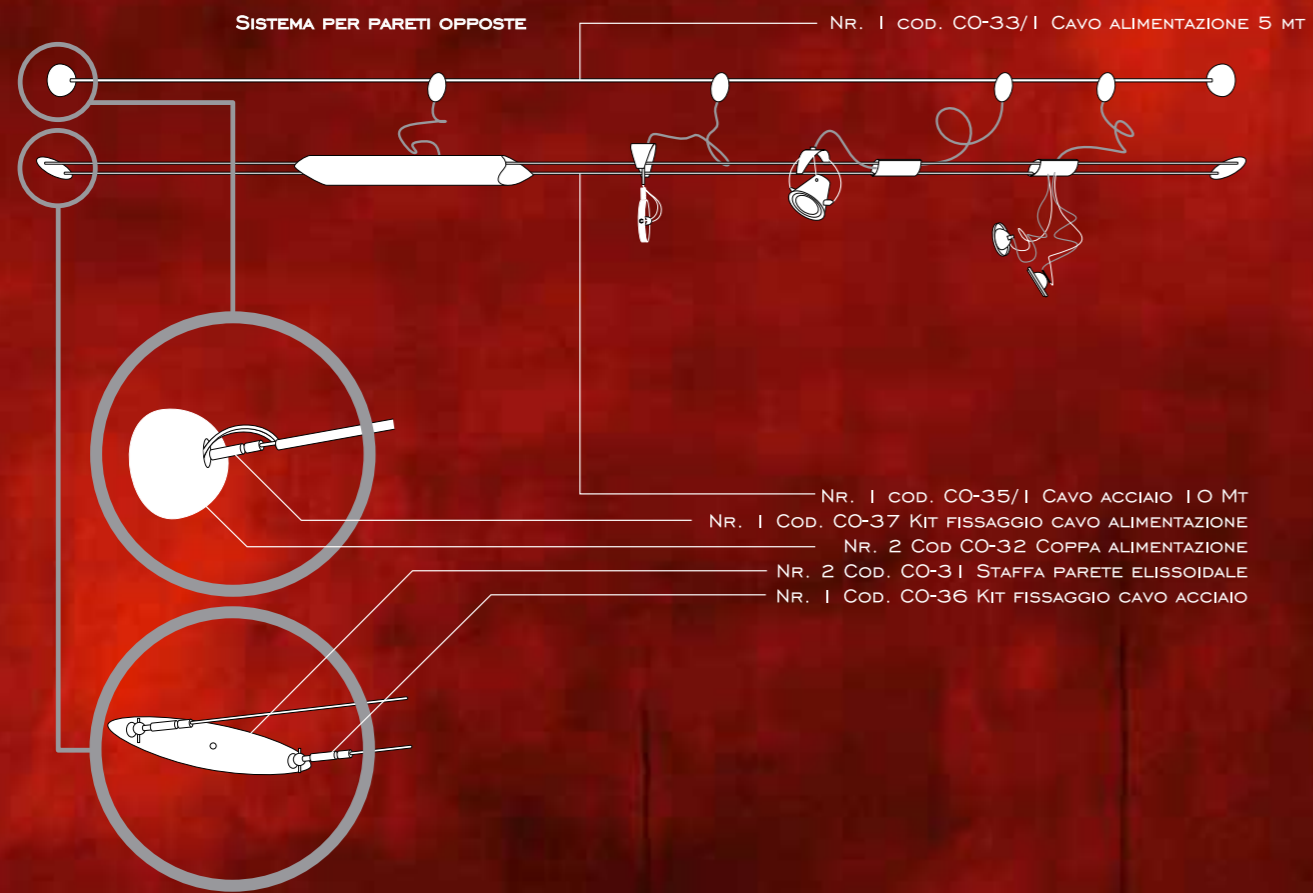

STAFFA PER ANGOLO 90°

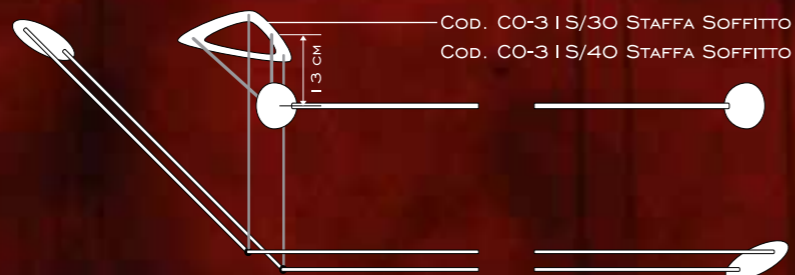
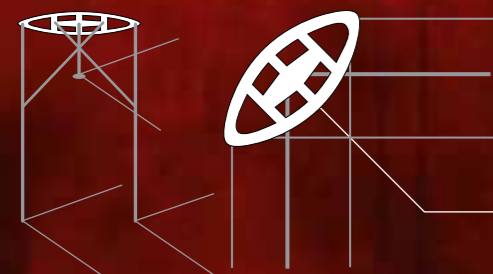

**SISTEMA PER SOFFITTO - PARETE FRONTALE**

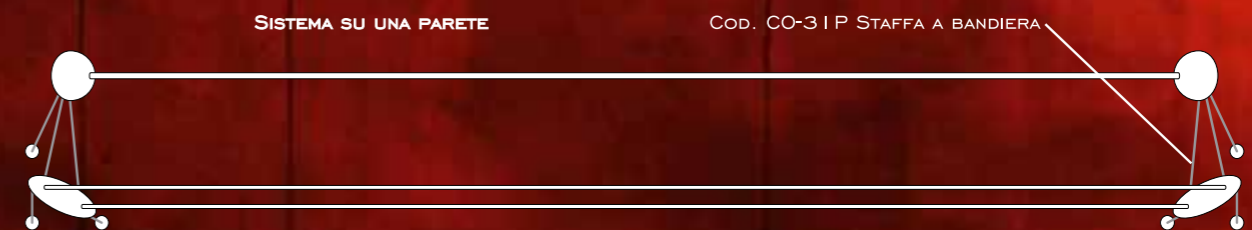

**SISTEMA PER SOFFITTO - PARETE LATERALE**

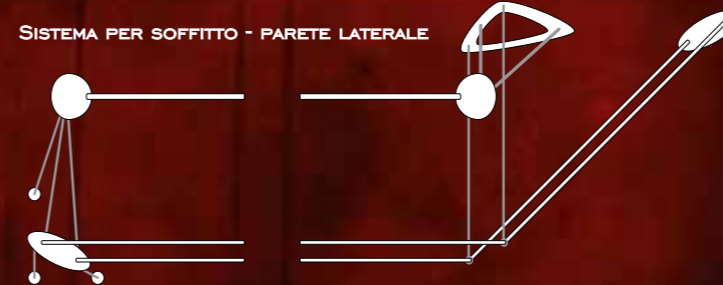

**SISTEMA ANGOLO - ANGOLO**

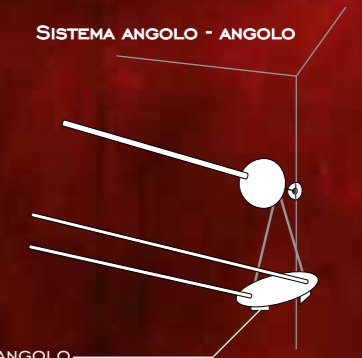

Ho navigato a lungo, trovato quel che cercavo e oggi posso offrire una risposta alle tue e alle mie esigenze: è nato il Sistema Colombo!

Un piccolo ovetto in policarbonato con tre lamelle inserite all'interno, preleva tensione da un cavo teso alimentando un qualsiasi utilizzatore.

Facile e unico.

*l' "OVO" di Colombo.*

*I have travelled far and wide, found what I was searching for and now I am able to provide an answer to all your, and my needs: the COLOMBO SYSTEM is here!*

*A small polycarbonate egg with three small internal blades, draws power from an electric cable, supplying any type of appliance.*

*Simple and unique. Like an egg!*





Cascina Marcantonio - AQUI TERME (AL)



Studio Privato  
Private Studio



Locanda del SANTO UFFIZIO - PENANGO (AT)



Cascina Marcantonio - AQUI TERME (AL)



INVERIGO HOTEL - Gruppo Plinio - INVERIGO (CO)

## ART E LIGHT

Riverberata, riflessa, propagata, scandita la luce è sempre accorsa alle richieste dell'arte. Talvolta è la luce a chiedere di lei. Non sempre la trova: l'Arte, si sa, è sempre molto occupata tra Musei e Atelier e sulla bocca di tutti. Ma quando si incontrano la materia si concede nuove vibrazioni e l'effetto è sorprendente.

## ART E LIGHT

*Reverberated, reflected, propagated, articulated, light has always met art's needs. Sometimes it is light that has need of Art. It doesn't always get it: Art, it is well known, is forever busy between Museums and Atelier and is on everyone's lips. But when they do meet, there are new vibrations and the effect is astonishing.*



RED PASSION



SCIVOLI'AMO



LADY ENT



Casa Privata  
Private House



I vestiti di Cina.  
Cina's dress.



Sala del pensiero (Fabbrica LUCIFERO)  
The All of Thought (Lucifero factory)



Casale Monferrato - Museo Civico - Gipsoteca Bistolfi.  
Casale Monferrato - Town museum - Bistolfi gallery of plaster casts.





# LE VANITÀ DI LUCIFERO

21 - 28 GIUGNO 2006 CHIESA DI SANTA CROCE

Non c'è modestia senza vanità.

(Roberto Gervaso)

Si parla poco quando non è la vanità a farci parlare.

(François de La Rochefoucauld)

Ci si sbaglierà raramente, attribuendo le azioni estreme alla vanità, quelle mediocri all'abitudine e quelle meschine alla paura.

(Nietzsche)

L'adulazione è una moneta falsa che ha corso solo grazie alla nostra vanità.

(François de la Rochefoucauld)

La Vanità è decisamente il mio peccato preferito.

(Al Pacino "l'Avvocato del Diavolo")

La vanità è alla base di tutto, anche la coscienza non è altro che vanità interiore.

(Gustave Flaubert)

Ciò che rende la vanità degli altri insopportabile, è che offende la nostra.

(François De La Rochefoucauld)



## LE VANITÀ DI LUCIFERO.

Peccato, tentazione, mistero. Lucifero sa come incantare gli animi con la bellezza e la magia della Luce. E se, come recitò Al Pacino, la vanità è il vostro peccato preferito, allora l'eleganza delle nuove icone non può che esservi tentatrice. Nella chiesa sconsacrata di Santa Croce a Villastellone si sono mostrate in tutto il loro fascino sensuale le regine dell'Oriente, gli scatti per il Catalogo 2007, in anteprima.

Geishe, guerriere, donne misteriose quali testimonial di un mondo sconosciuto e ammaliante che vi seguirà tra le creazioni di luce di Lucifero.

Per una volta, non resistete alle vanità.

## LUCIFERO'S VANITIES.

Walter Dang - Atelier Couture.

*Sin, temptation, mystery. Lucifero knows how to capture the soul with the beauty and magic of Light. And as one of Al Pacino's film characters said: "Vanity is your favourite sin", then the elegance of new icons cannot but tempt you. The deconsecrated church, Santa Croce in Villastellone was host to the Oriental Queens in all their sensual splendour giving a preview of the shots for the 2007 Catalogue.*

*Geishe, warriors, mysterious women all testimonial to an unknown and charming world that will follow you among Lucifero's creations.*

*For once, succumb to Vanity.*







## LA FORZA DELLA LUCE

15 - 30 SETTEMBRE 2006  
 ECOMUSEO SOGNO DI LUCE - ALPIGNANO (TO) - ITALY

### LA FORZA DELLA LUCE

Quale luogo migliore per elogiare la luce se non dove la luce ha preso forma? Spieghiamoci meglio: Alessandro Cruto fu l'inventore del filamento di carbonio, piccolo, indispensabile componente della lampadina. L'ecomuseo di Alpignano, costruito sull'allora fabbrica di luce, l'opificio, ospita oggi le testimonianze di una scoperta tanto straordinaria. E Lucifero, con la stessa passione per tutto ciò che è ricerca e sperimentazione ha scelto questa suggestiva location per presentare le sue creazioni. Immagini impattanti a simboleggiare l'energia luminosa creata dal maestro della luce attraverso le sue opere d'arte. Non tutti possono avere in dono la forza della luce, ma con Lucifero, il virtuosismo scintillante della creatività vi avvolgerà in un turbinio di emozioni.



## THE POWER OF LIGHT

15 - 30 SETTEMBRE 2006  
 ECOMUSEO SOGNO DI LUCE - ALPIGNANO (TO) - ITALY

### THE POWER OF LIGHT

*What better place to praise light than where it was created? To better explain: Alessandro Cruto was the inventor of the carbon filament, the small but indispensable part of a light bulb. The Eco-Museum in Alpignano, which is built on the site of the "Light Factory" now holds the evidence of that extraordinary discovery. Lucifero, with the same passion for all things concerning research and experimentation, chose this atmospheric location to present its creations to the general public. Astonishing images used to symbolize the luminous energy created by the master of light through his works of art. The talent of the Power of Light is not given to everyone, but with Lucifero, its sparkling creativity will pick you up in a whirlwind of emotions.*

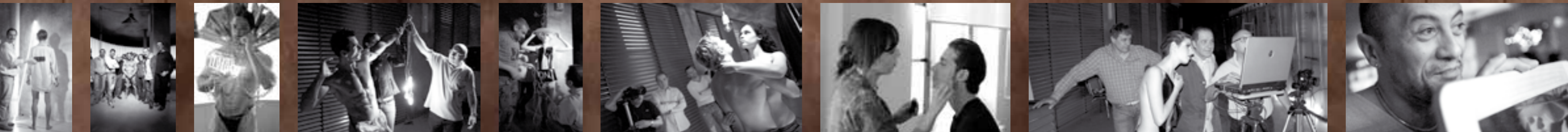
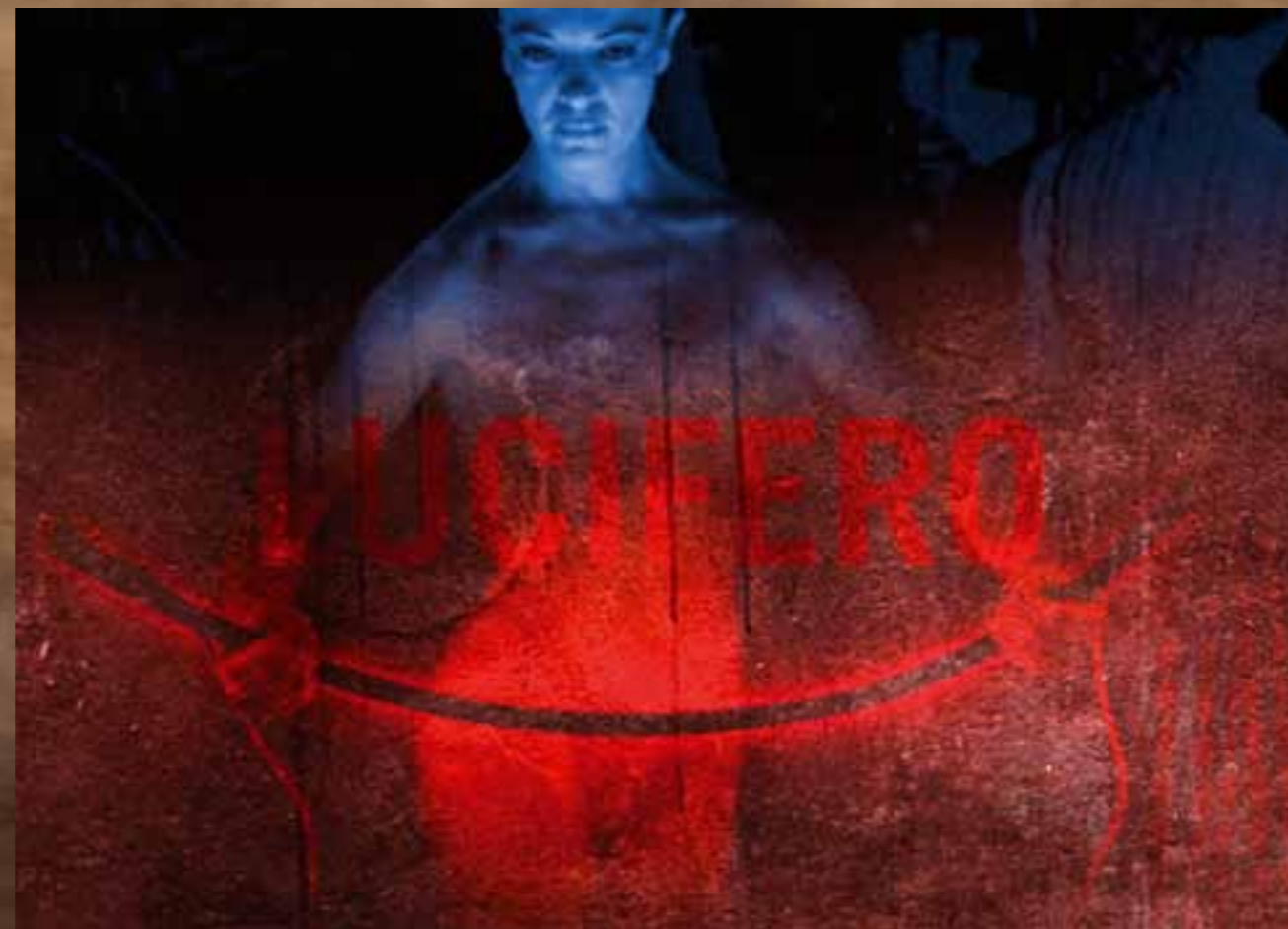





### LUCIFERO: PARATISSIMA 2008 - I PRODOTTIVORI

I prodottivori

Da una parte le insicurezze dell'uomo moderno, alla continua ricerca di conferme. Dall'altra la pubblicità: accattivante, coinvolgente... falsa.

Ed ecco che i prodotti materiali diventano un sogno di fuga e benessere: comprare, buttare, ricomprare. Acquistare più di quanto serve. Fagocitare tutto ciò che è disponibile, ora. Il vortice del consumismo irrompe nella quotidianità rendendo il mondo saturo di oggetti, spesso superflui.

Gli essere umani paiono ciechi di fronte alla piaga del consumo senza freni: maschera sugli occhi e ghiaccio nel cuore. Sono i "prodottivori", i nuovi cannibali dell'era contemporanea: un neologismo per un fenomeno certo non nuovo e che sta accompagnando la Terra alla catastrofe.

Ma noi vogliamo credere che la luce della mente potrà ancora illuminare la nostra vita.

The "Prodottivori"

From one side there are insecurities of modern people who are constantly in search for confirmation. From the other side, there is advertising: charming, attractive... and false.

The material products are becoming a dream, a dream for escape and well-being: to buy, to waste and to buy again. To buy more than we need. To phagocyte everything is available is possible, now. Irresponsible consumption is coming brutally into our everyday's life and our everyday's life is full with things, often superfluous.

Human being seem to be blind in front of the curse of consumption with no restrictions. One mask on the eye and ice inside the heart. We call them "prodottivori", the cannibals of modern times: a neologism for a phenomena which is not new and it is going to lead the earth toward a catastrophe.

Yet, we want to believe that the light inside our mind can still bring light into our life.



### LUCIFERO: LUCI D'ARTISTA A PIANEZZA - 2006



# Luce Divina

2008-9-8

La Luce Degli Angeli:

Origami di luce, origami di carta si trasformano in avvolgenti vesti per impreziosire i nostri angeli. Sono gli Angeli Luciferini, tra arte e nuvole, nuvole e arte.

Sullo sfondo il cielo, tra i capelli suggestioni arcaiche che rimandano ad atmosfere oniriche: Raffaello, il Botticelli, ..... sono i grandi del passato a far da testimoni con aulica pittura.

Volate leggeri nell'aria vibrante, volate in mezzo a noi.

Con energia infinita, ci osservano, ci assistono, ci supportano nel nostro cammino verso la conoscenza: gli angeli. Risplende Lucifero in mezzo a loro, sommo maestro portatore di luce, tra peccato, virtù e vanità.

"I nostri occhi non vedono, ma apriamo il cuore all'intelletto. Così scopriremo la luce".

Lucifero e la luce, Lucifero e i suoi corpi luminosi. Giorno, notte, alba o tramonto, è l'arte di Lucifero a farsi spazio tra le nuvole e ad accompagnare i momenti della vita. Con angelica ironia: nove creazioni di illuminata poesia, nove angeli protagonisti dell'inesauribile iridescenza "luciferina".

The light of Angels

Origami of light and paper transform into delicate clothes which splendour our angels. They are Lucifer's disciples, between art and clouds, clouds and art. On a backdrop of sky, ancient emotions in the angel hair bring to mind a dream like atmosphere: Raffaello, Botticelli, the grand masters of the past who gave testimony their fine works of art.

"Fly gently in the vibrant air, fly among us".

With endless energy, they watch us, they aid us, they guide us on our way towards knowledge: The angels. Lucifer is the brightest among them, the supreme master, the carrier of light, between sin, virtue and vanity.

"Our eyes cannot see, but let us open our hearts to intellect. That way we can find the light".

Lucifer and the light, Lucifer and his luminous bodies. Day, night, sunrise or sunset, it is Lucifer's art which makes space among the clouds and accompanies life's events. Created with angelic iron: nine creations of enlightened poetry, nine angels which are centre players in the endless "Lucifero" iridescence.



*Per questo sei stato precipitato negli inferi,*





*Tu eri un modello  
pieno di sapienza  
perfetto in bellezza  
Eri come un cristallo  
in te posi sul monte santo  
e camminavi in me  
Perfetto tu eri nella tua  
da quando sei stata creata  
finché fu trovata la tua  
Crescendo i tuoi commetti  
di sei compito di volare  
sai ho succiato dal mio  
ti ho fatto sereno e  
me alle pietre si fu*

PROGETTO: LUCIFERO  
RIPRESE FOTOGRAFICHE: IMMAGINARIO - MENEGATTI & MANFREDI  
COSTUMI: AGOSTINO PORCHIETTO  
MAKE-UP: GLORIA CORTIGIANI  
PROGETTO GRAFICO E POST PRODUZIONE FOTOGRAFICA: MALART - LUCA MARIETTA A.

RINGRAZIAMENTI SPECIALI:  
TESTI: LAURA SCIOLLA  
LOCATION: HOTEL BOSTON, TORINO - ITALY

PLAN: LUCIFERO  
PHOTOGRAPHIC: IMMAGINARIO - MENEGATTI & MANFREDI  
COSTUMI: AGOSTINO  
MAKE-UP: GLORIA CORTIGIANI  
GRAPHIC PROJECT AND PHOTOGRAPHIC POST PRODUCTION: MALART - LUCA MARIETTA A.

SPECIAL THANKS:  
COPY WRITER: LAURA SCIOLLA  
LOCATION: HOTEL BOSTON, TORINO - ITALY

Lucifero illumina la Sfilata di Walter Dang - Facoltà di Architettura - (TO)







**LUCIFERO**<sup>®</sup>  
ILLUMINAZIONE

LUCIFERO ILLUMINAZIONE S.R.L.

VIA MOLINI 35 - 10098 RIVOLI - TORINO - ITALY  
TEL. ++39 011.959.84.33 - FAX ++39 011.957.49.61  
HTTP://WWW.LUCIFEROILLUMINAZIONE.COM  
E-MAIL: LUCIFERO@LUCIFEROILLUMINAZIONE.COM